



Conveyor Solutions CS70



Primary Packaging
Product Catalogue

“Whatever your logistic needs,
we can offer a conveyor solution.
Our flexible systems – primary
and secondary packaging –
for single and multi packages,
can transport your goods from
one end to another.”



Fredriksons conveyor systems handle goods with a width from 20 mm up to 600 mm.

Conveyor Solutions for your material handling needs

Fredriksons offers a single source of integrated conveyor solutions for a variety of industries. We provide complete solutions, from development to production, automation solutions, software, installation and service. Our product portfolio consists of package conveyors, vertical conveyors, accumulators, elevators and supporting equipment for transporting primary and secondary goods. Our customers are leading companies worldwide who need advanced, cost-effective packaging equipment and reliable deliveries.

- Cost effective conveyor systems that give years of reliable service
- Robust and expandable construction
- Easy to install, clean and maintain
- High speed, up to 120 metres per minute
- Few standard components minimises spare parts
- Patented solutions

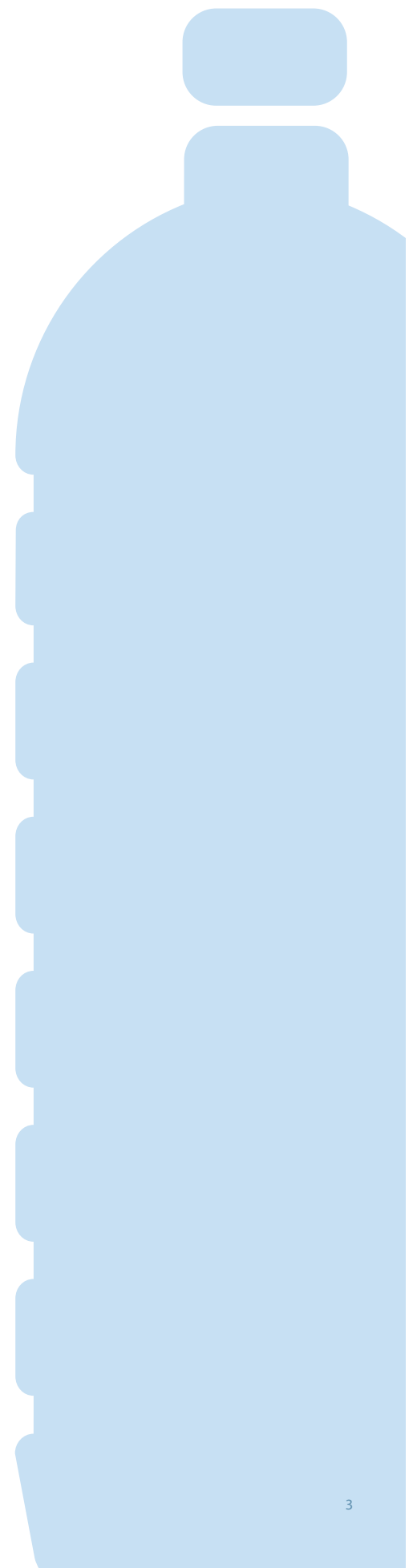

Contents

Primary Packaging System	6
Cost and Environmental Efficiency in Our Systems	8
Product Range	9
Vertical Bend $\pm 10^\circ$	10
Adjustable Glide Curve	11
Glide Curve	12
Wheel Curves	14
End Unit	17
Straight Conveyors	18
Drive Unit (Motor at the side)	19
Drive Unit (Motor on top)	21
Drive Unit (Motor below)	23
Drive & End Unit	25
Drive & End Unit (Motor on top)	27
Drive & End Unit (Motor below)	29
Switch 1-2	31
Switch 2-1	33
Switch 2-1 (Motor On Top)	35
Switch 2-1 (Motor Below)	37
Belt Brake	39
Hose Brake	40
Package Trap (Newton)	41
Package Trap (Blow)	42
Package Trap (Push)	43
Chains	44
Chain Removal Section	45
Telescopic Conveyor	46
Junction Kit	47
Junction Kit - Curve	48
Junction Kit - Wheel Curve	48
Sensor Kit	49
Washing Unit (No Drain)	50

Washing Unit (With Drain)	50
Drip Tray (Straight Conveyor)	51
Drip Tray (Glide Curve)	51
Drip Tray (Wheel Curve with Drain)	51
Legs (Conveyor)	52
Legs (Motor)	53
Strut	54
Chain Tool	55
Drill Fixture	55
Rivet Tool	55



Primary Packaging System

Our conveyors are based on a stainless steel body with low friction slide rails guiding and plastic multi-flex chain. Products to be conveyed travel directly on a conveyor, or on pallets/carriers. Products handled have a weight from a few grams up to 30 kg.

Material			
Stainless steel	EN 1.4301	ASTM 301	SS2333



Our conveyor system for primary packaging, CS70, has a superior hygienic design. The side plates of the conveyor body have been designed with extra holes to facilitate easy cleaning, inspection and draining.

The conveyor width is adjustable from 40-120 mm. Recommended rail width is package width + max 10%, max 6 mm. CS70 has a solid, robust construction and can easily be adjusted to particular needs.

Our conveyor systems are flexible and can be customised according to customer requests and needs. Different railing solutions are available depending on your needs, below is a sample of our standard rail width.

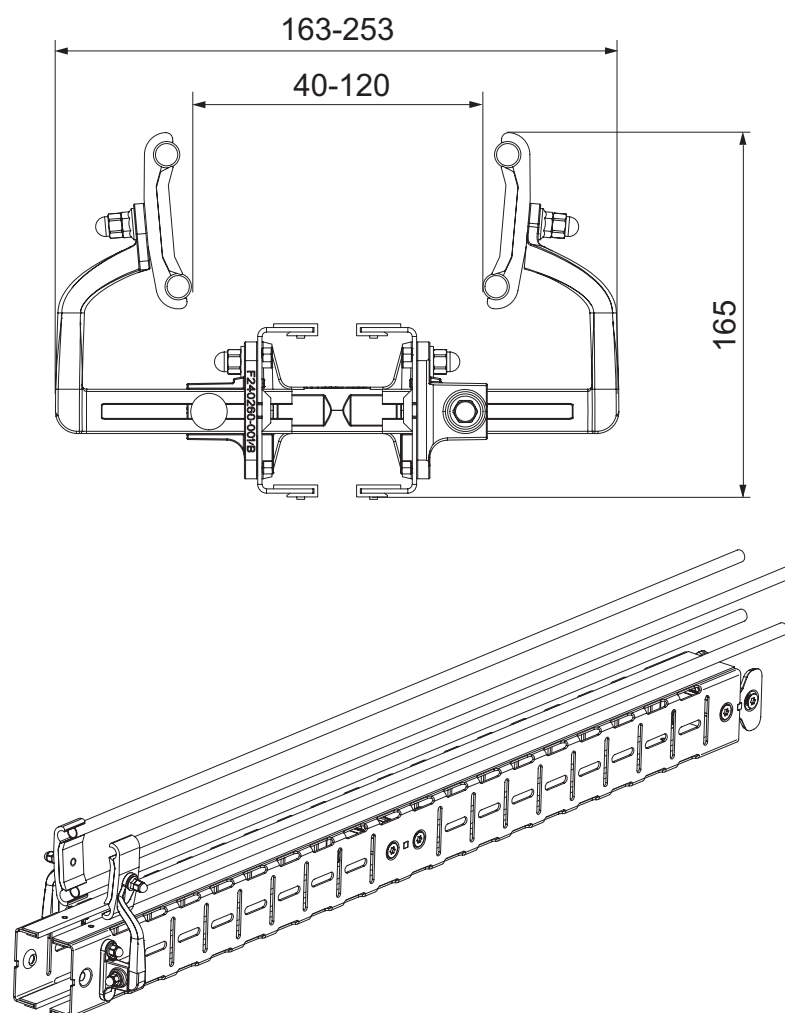



Cost and Environmental Efficiency in Our Systems

In a complete conveyor system it is important not to exceed the distance between drive and end unit. The table on the right shows the different component values equal to the resistance compared to a straight conveyor. The total length of the components between drive and end unit must not exceed for singel packs: 20 m.

Due to environmental considerations we recommend wheel curves before glide curves. A lower friction reduces the energy consumption and wear.

Component	Length (m)
Straight conveyor	3.0
Drive unit	0.75
Drive and End unit	1.0
End unit	0.5
Package trap	1.5
Glide Curve 15°	2.0
Glide Curve 45°	2.5
Wheel Curve 45°	1.0
Wheel Curve 90°	1.5
Wheel curve 180°	2.5
Switch	1.5-1.75

Product Range



Vertical Bend

$\pm 10^\circ$

Fredriksons Vertical bend is used for raising or lowering the conveyor.

Proper incline angle is $\pm 10^\circ$.

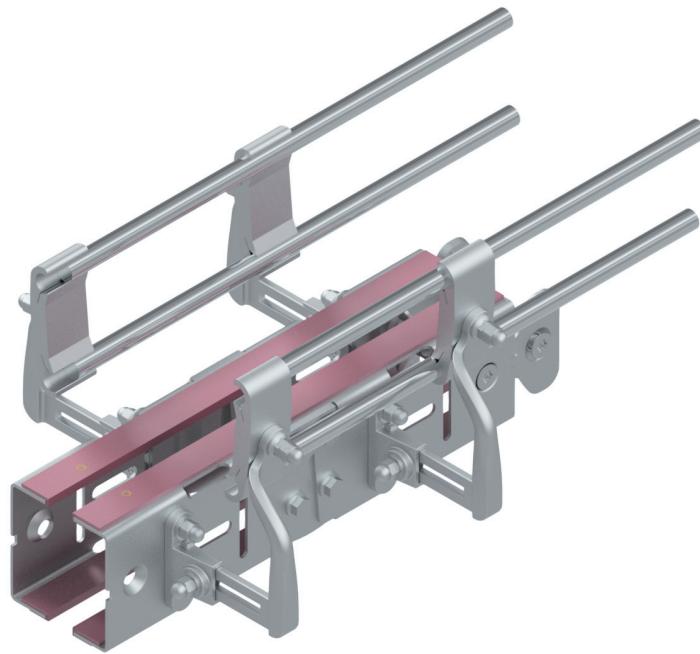

Part Number	Railing Width mm	Chain Length m	Weight kg
F240135-1120-00	40-120	0.6	3.1

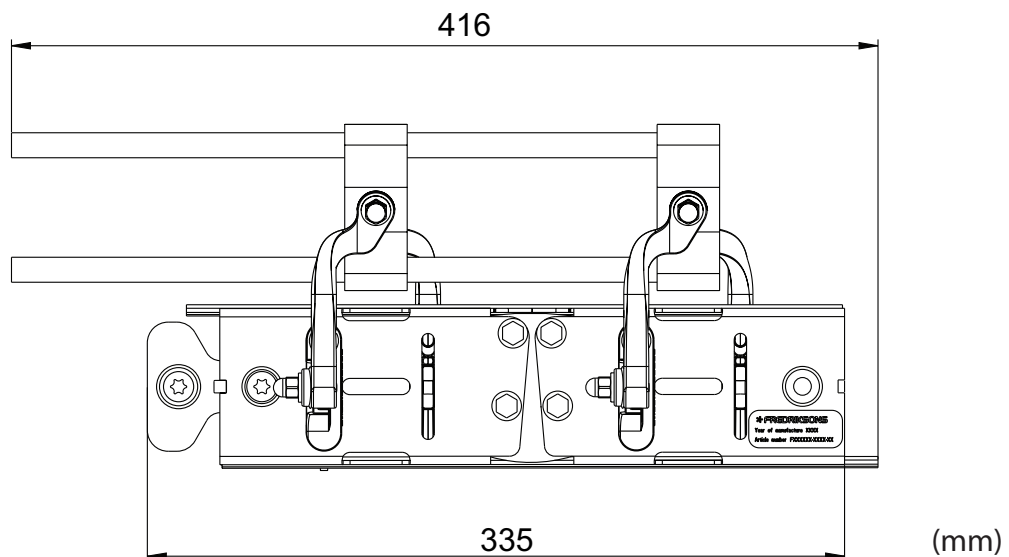

Adjustable Glide Curve

Fredriksons Adjustable Glide Curve is an excellent choice for smooth turns between 0-15°.

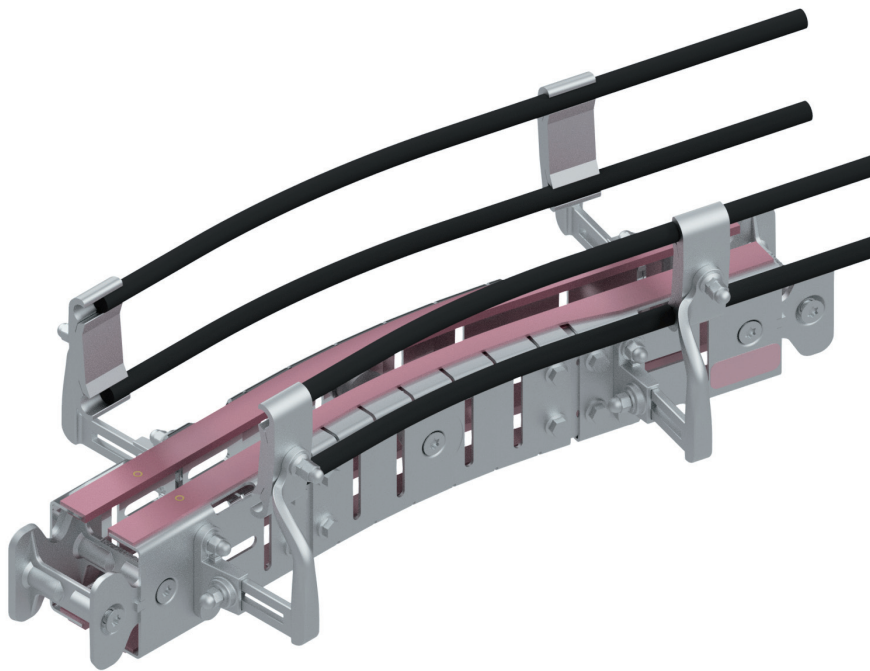

Part number	Railing width mm	Chain Length m	Weight kg
F240140-1120-00	40-120	1.2	5.8

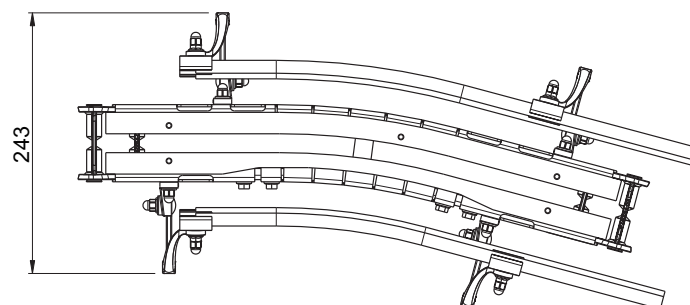
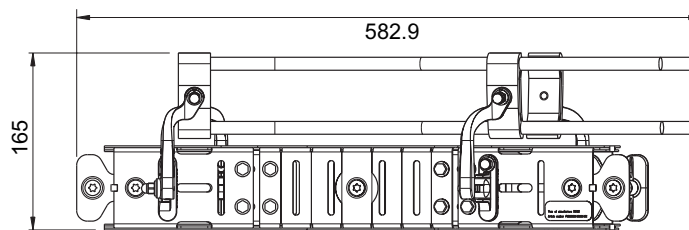

(mm)

Glide Curve

Fredriksons Glide Curves are available in the fixed angles 15°, 30°, 45° and 90°.

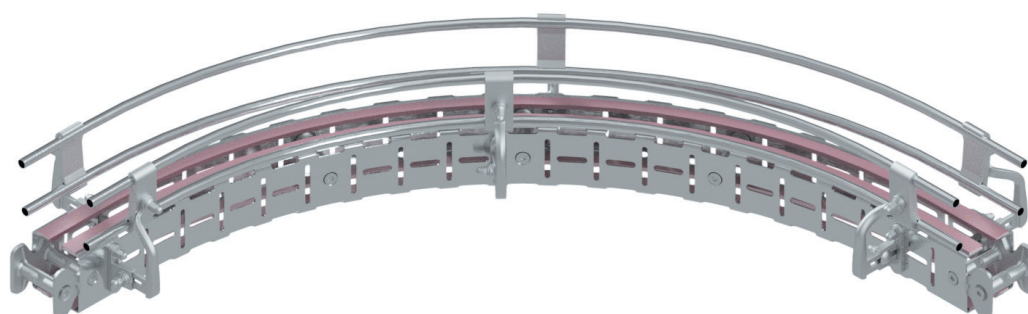

Part number	Variants °	Railing width mm	Chain Length m	Weight kg
F240106-1120-080	90	80	2.7	8.5
F240106-1120-106	90	106	2.7	8.5
F240107-1120-080	45	80	1.7	5.7
F240107-1120-106	45	106	1.7	5.7
F240108-1120-080	30	80	1.4	5.1
F240108-1120-106	30	106	1.4	5.1
F240109-1120-080	15	80	1.1	4.1
F240109-1120-106	15	106	1.1	4.1

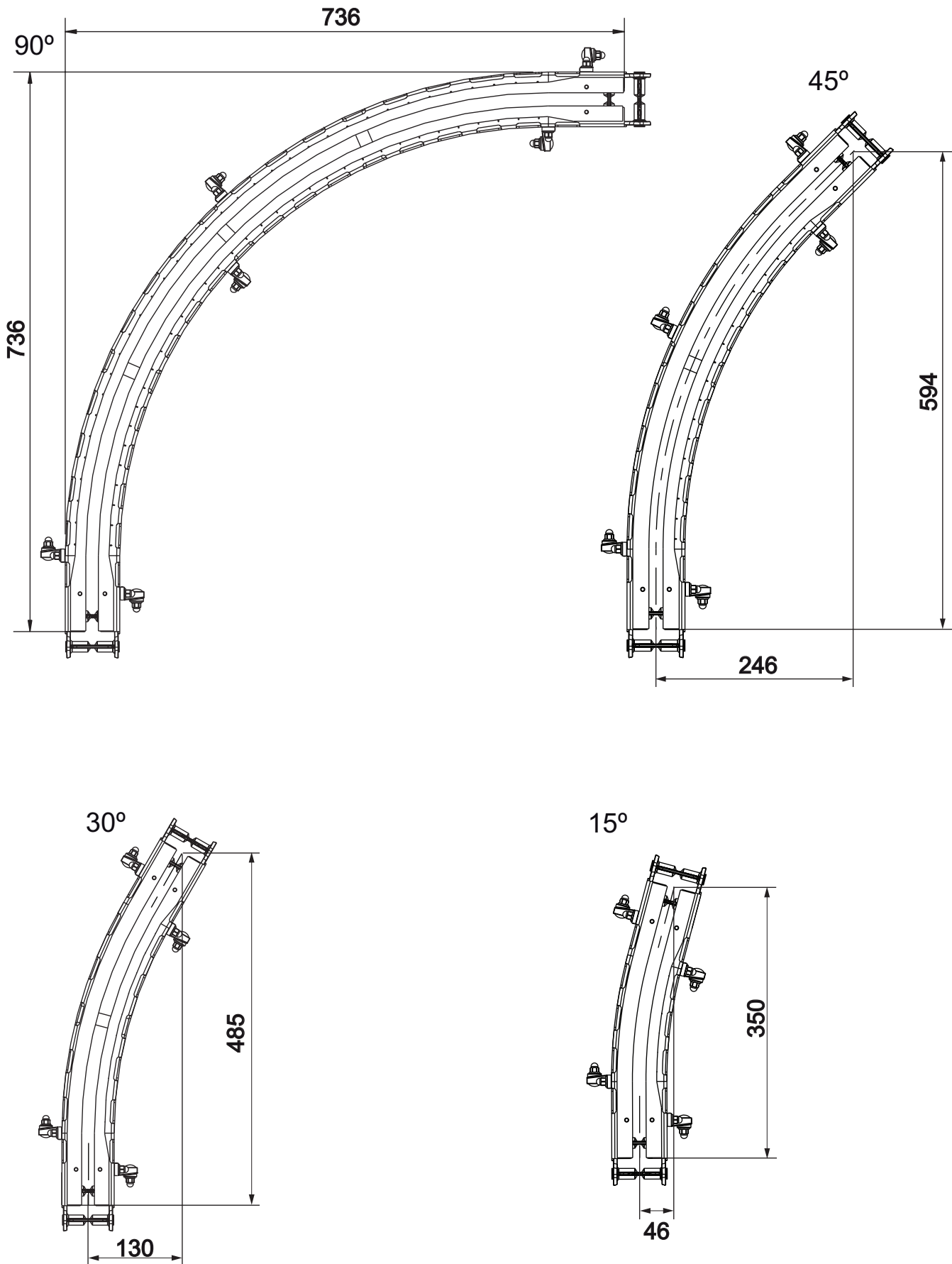

(mm)

Wheel Curves

Fredriksons Wheel curves are available in the fixed angles 45°, 75°, 90°, 105°, 135°, 150°, 165° and 180°

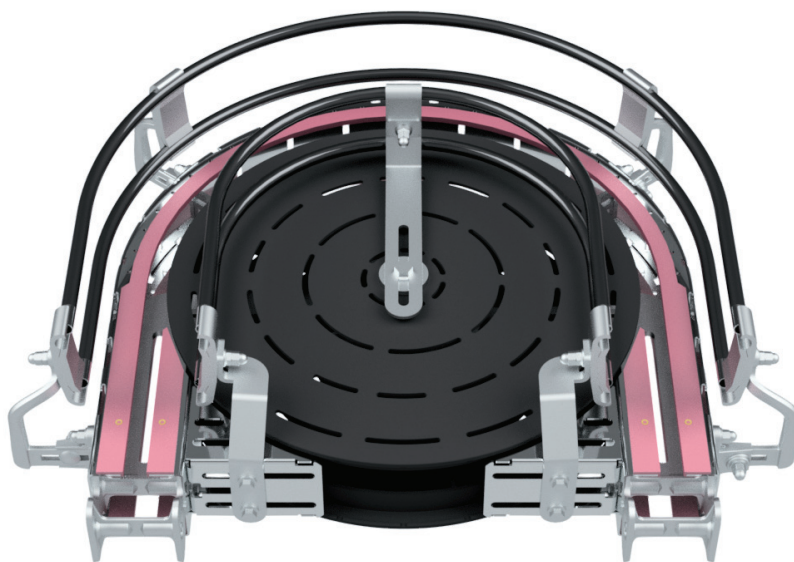

Part number	Variants °	Railing width mm	Chain Length m	Weight kg
F240055-2120-065	45	65	1.2	8.6
F240055-2120-080	45	80	1.2	8.6
F240055-2120-090	45	90	1.2	8.6
F240055-2120-106	45	106	1.2	8.6
F240055-2120-120	45	120	1.2	8.6
F242115-2120-065	75	65	1.4	8.9
F242115-2120-080	75	80	1.4	8.9
F242115-2120-090	75	90	1.4	8.9
F242115-2120-106	75	106	1.4	8.9
F242115-2120-120	75	120	1.4	8.9
F240126-2120-065	90	65	1.6	9.0
F240126-2120-080	90	80	1.6	9.0
F240126-2120-090	90	90	1.6	9.0
F240126-2120-106	90	106	1.6	9.0
F240126-2120-120	90	120	1.6	9.0

Part number	Variants °	Railing width mm	Chain Length m	Weight kg
F243570-1120-065	105	65	1.8	9.8
F243570-1120-080	105	80	1.8	9.8
F243570-1120-090	105	90	1.8	9.8
F243570-1120-106	105	106	1.8	9.8
F243570-1120-120	105	120	1.8	9.8
F241389-2120-065	135	65	2.0	10.1
F241389-2120-080	135	80	2.0	10.1
F241389-2120-090	135	90	2.0	10.1
F241389-2120-106	135	106	2.0	10.1
F241389-2120-120	135	120	2.0	10.1
F243501-1120-065	150	65	2.1	10.3
F243501-1120-080	150	80	2.1	10.3
F243501-1120-090	150	90	2.1	10.3
F243501-1120-106	150	106	2.1	10.3
F243501-1120-120	150	120	2.1	10.3
F243571-1120-065	165	65	2.3	10.5
F243571-1120-080	165	80	2.3	10.5
F243571-1120-090	165	90	2.3	10.5
F243571-1120-106	165	106	2.3	10.5
F243571-1120-120	165	120	2.3	10.5
F240127-2120-065	180	65	2.3	10.6
F240127-2120-080	180	80	2.3	10.6
F240127-2120-090	180	90	2.3	10.6
F240127-2120-106	180	106	2.3	10.6
F240127-2120-120	180	120	2.3	10.6

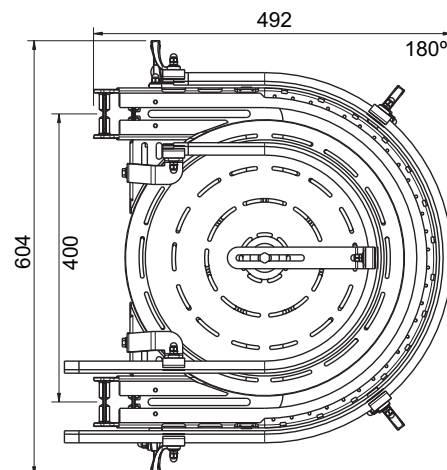
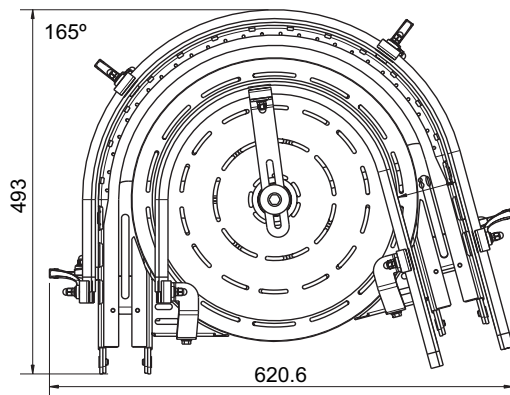
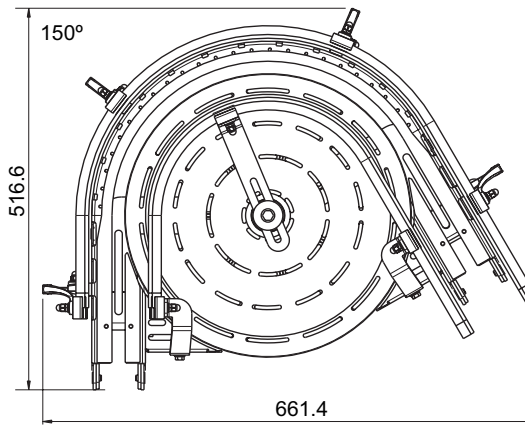
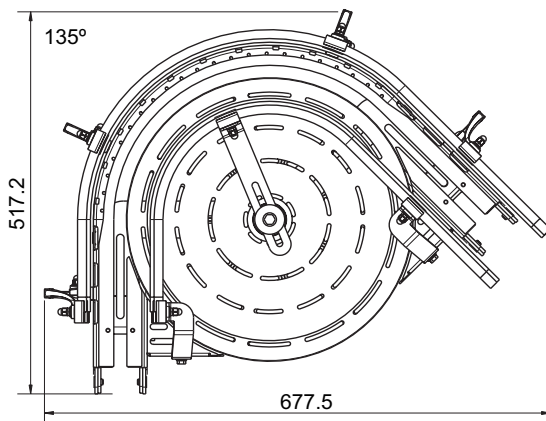
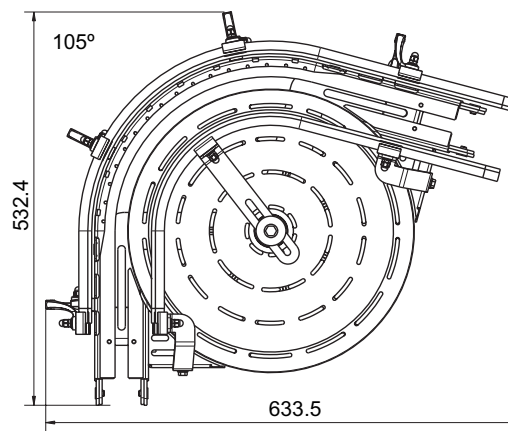
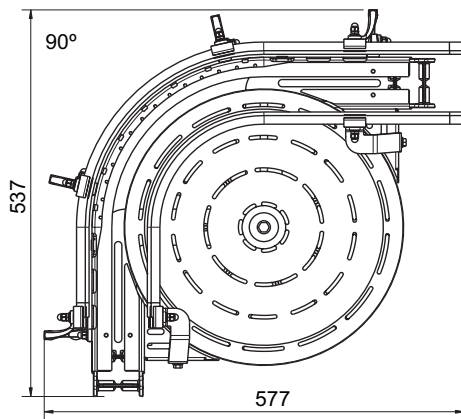
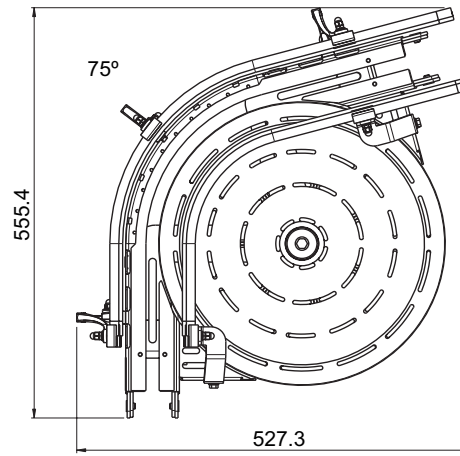
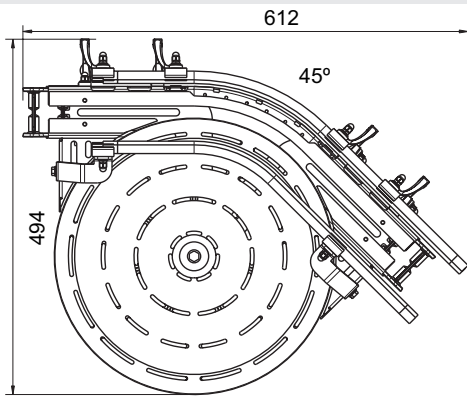

(mm)

End Unit

Fredriksons End Unit together with CS70 chain provides a safe area without trapping risks.

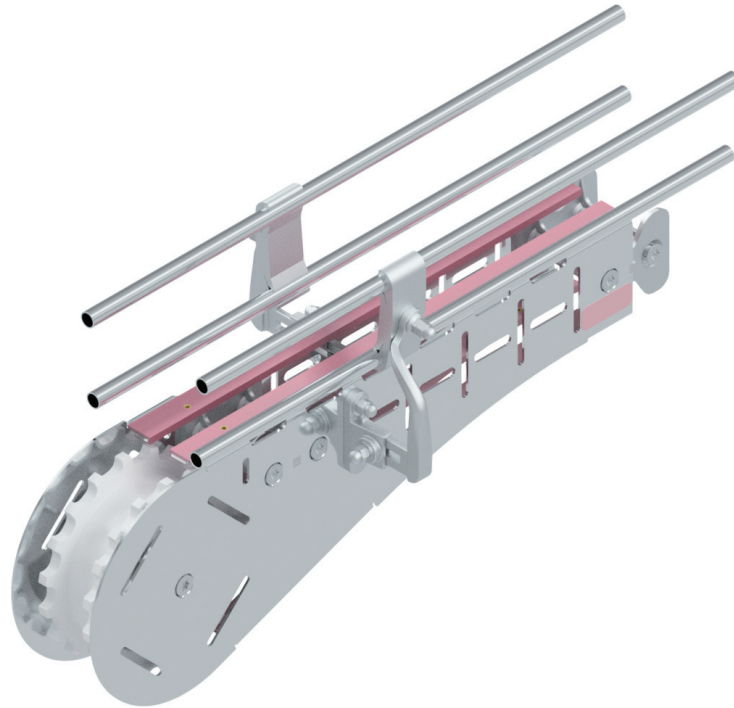

Part number	Railing width mm	Chain Length m	Weight kg
F238452-2120-00	40-120	1.1	4.9

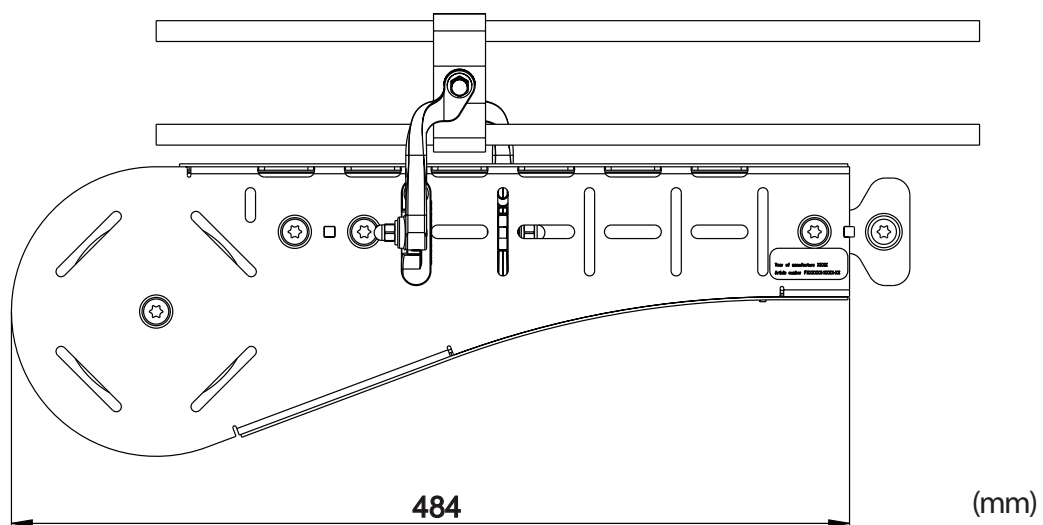

Straight Conveyors

Fredriksons Straight Conveyors is available in lengths, 250, 500, 1000, 2000 and 3000 mm.

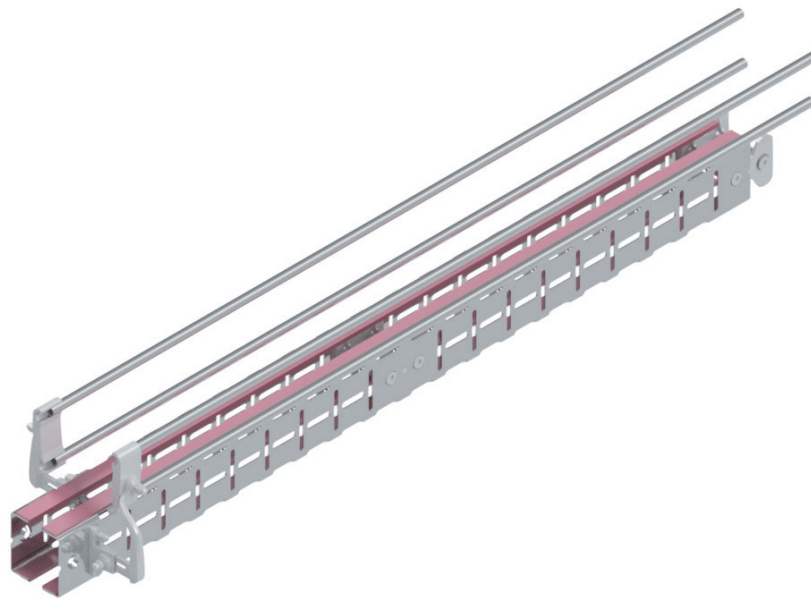

Part number	Lenght L mm	Railing width mm	Chain Length m	Weight kg
F240218-1120-00	250	40-120	0.5	2.3
F240302-1120-00	500	40-120	1	3.4
F238423-1120-00	1000	40-120	2	6.0
F242293-1120-00	2000	40-120	4	11.2
F238424-1120-00	3000	40-120	6	16.8

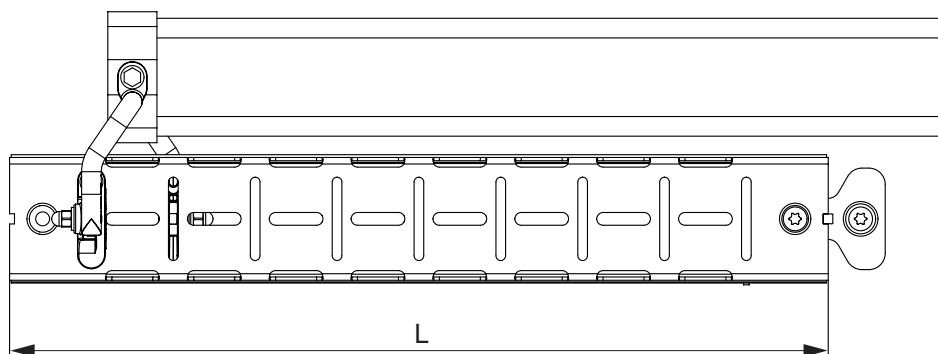

Drive Unit (Motor at the side)

Fredriksons Drive Unit are available in left and right versions.

Illustration: F243229-1121-01

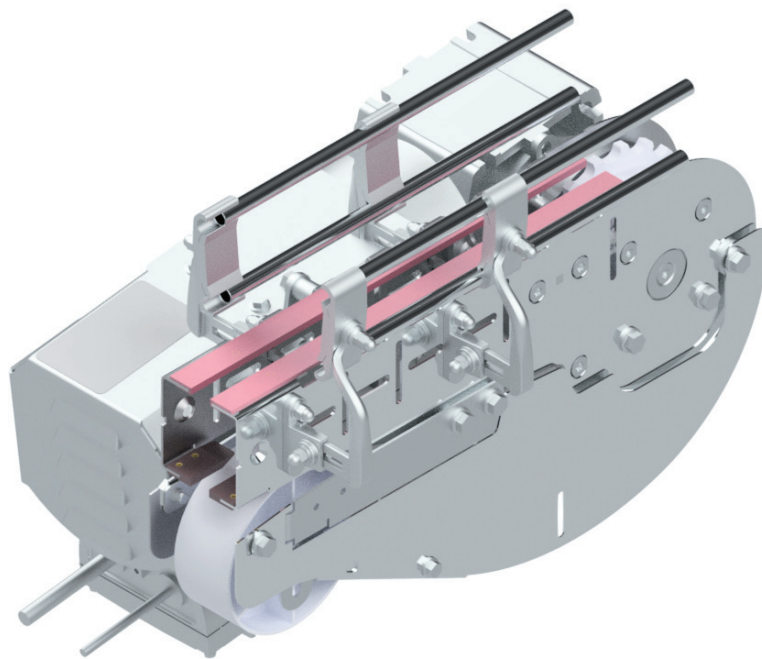

Part number	Variants	Motor	Chain Length m	Weight kg
F243229-1121-01	Left	NORD NORDACON	1.2	56,5
F243229-1122-01	Right	NORD NORDACON	1.2	56,5
F243229-1121-02	Left	SEW MOVIMOT EIP	1.2	12,5
F243229-1122-02	Right	SEW MOVIMOT EIP	1.2	12,5
F243229-1121-03	Left	SEW MOVIMOT PN	1.2	12,5
F243229-1122-03	Right	SEW MOVIMOT PN	1.2	12,5
F243229-1121-04	Left	SEW motor	1.2	24,6
F243229-1122-04	Right	SEW motor	1.2	24,6
F243229-1121-05	Left	NORD motor	1.2	25,3
F243229-1122-05	Right	NORD motor	1.2	25,3

NORD, NORDACON

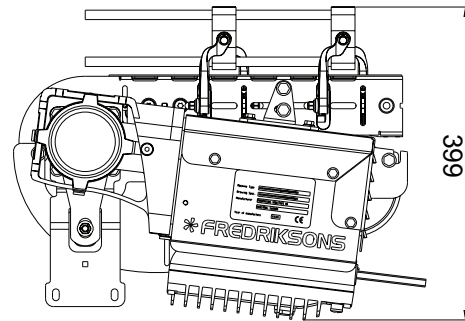
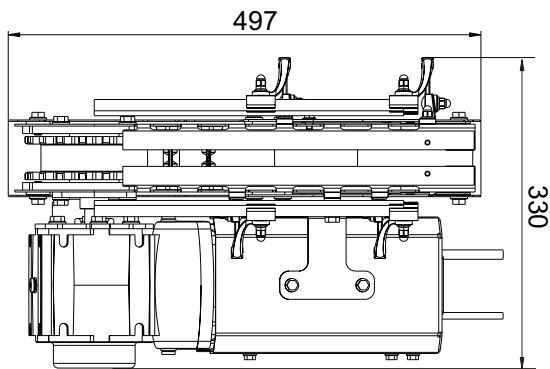

SEW, MOVIMOT EIP/PN

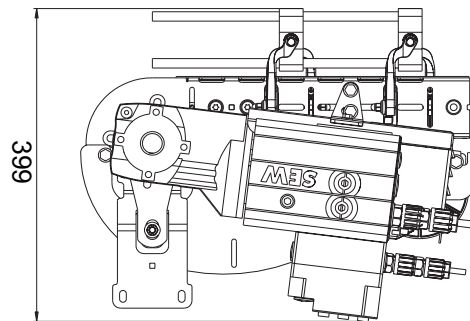
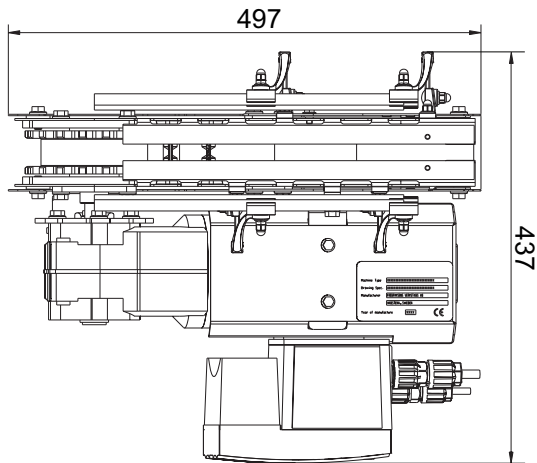

SEW, STANDARD

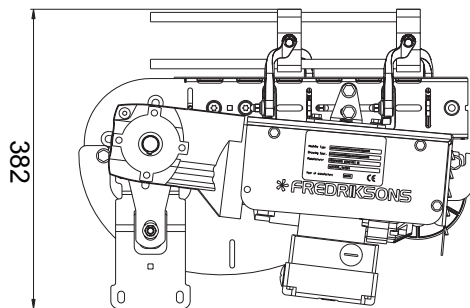
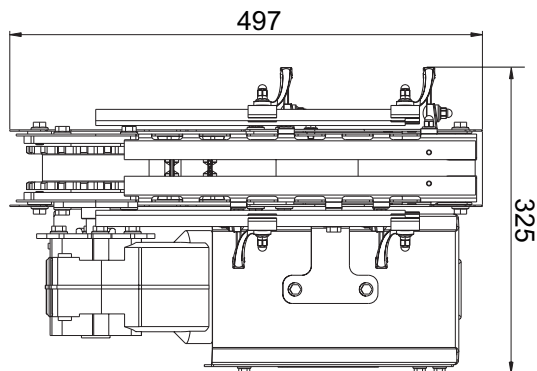

NORD, STANDARD

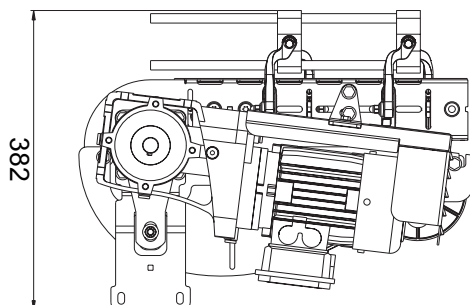
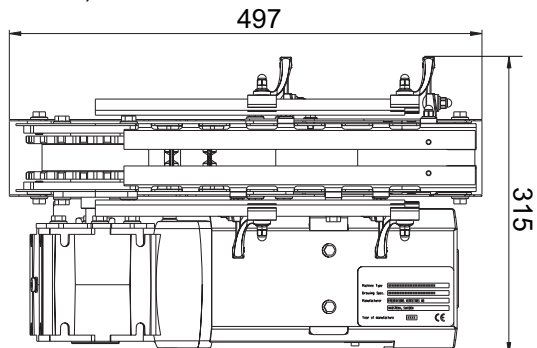

(mm)

Drive Unit (Motor on top)

Fredriksons Drive Unit are available in left and right versions.

Illustration: F243229-1123-01

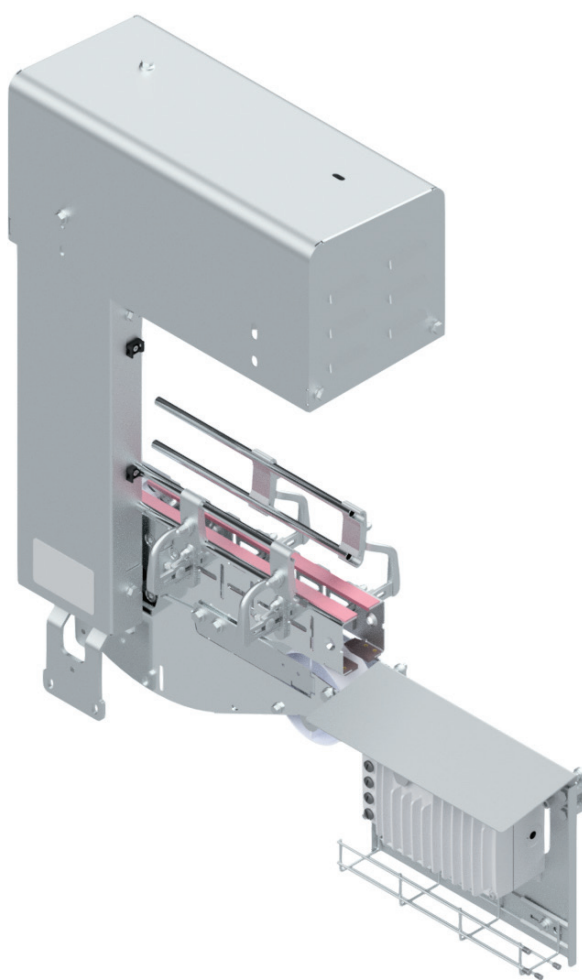

Part number	Variants	Motor	Chain Length m	Weight kg
F243229-1123-01	Left	NORD NORDACON	1.2	45,5
F243229-1124-01	Right	NORD NORDACON	1.2	45,5
F243229-1123-02	Left	SEW MOVIMOT EIP	1.2	45,3
F243229-1124-02	Right	SEW MOVIMOT EIP	1.2	45,3
F243229-1123-03	Left	SEW MOVIMOT PN	1.2	45,4
F243229-1124-03	Right	SEW MOVIMOT PN	1.2	45,4

NORD, NORDACON

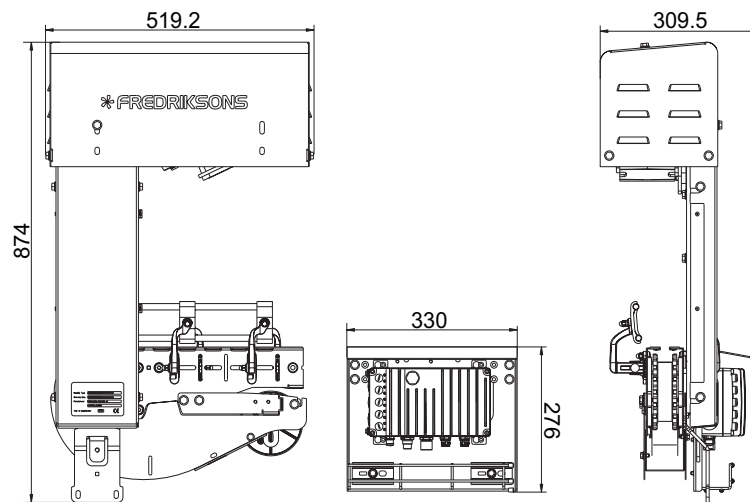

SEW, MOVIMOT EIP

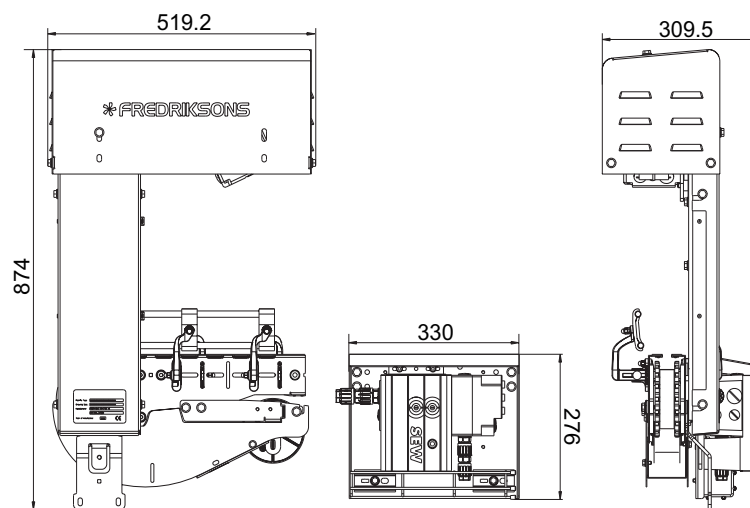

SEW, MOVIMOT PN

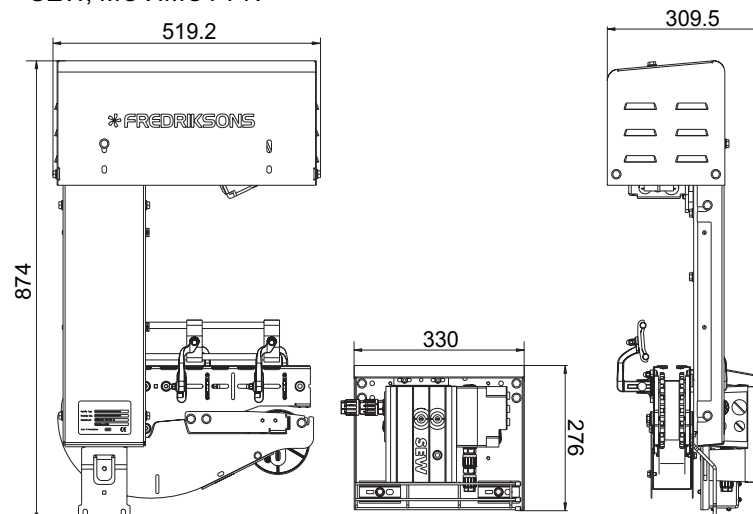

(mm)

Drive Unit (Motor below)

Fredriksons Drive Unit are available in left and right versions.

Illustration: F243229-1125-01

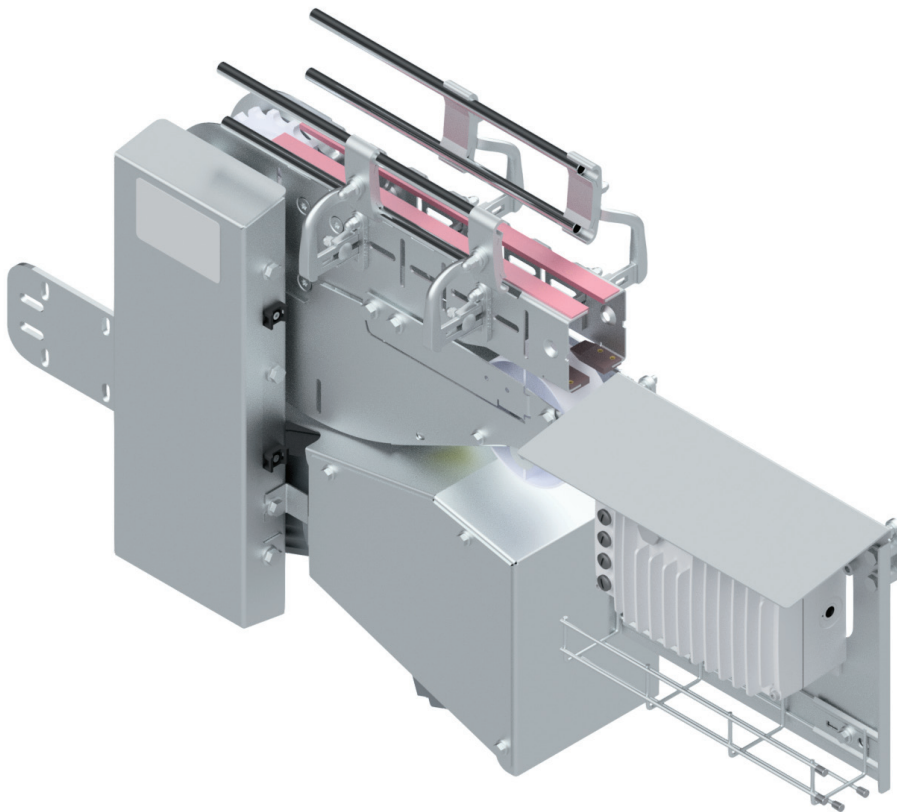

Part number	Variants	Motor	Chain Length m	Weight kg
F243229-1125-01	Left	NORD NORDACON	1.2	40
F243229-1126-01	Right	NORD NORDACON	1.2	40
F243229-1125-02	Left	SEW MOVIMOT EIP	1.2	39,6
F243229-1126-02	Right	SEW MOVIMOT EIP	1.2	39,6
F243229-1125-03	Left	SEW MOVIMOT PN	1.2	39,6
F243229-1126-03	Right	SEW MOVIMOT PN	1.2	39,6
F243229-1125-04	Left	SEW motor	1.2	33,7
F243229-1126-04	Right	SEW motor	1.2	33,7

NORD, NORDACON

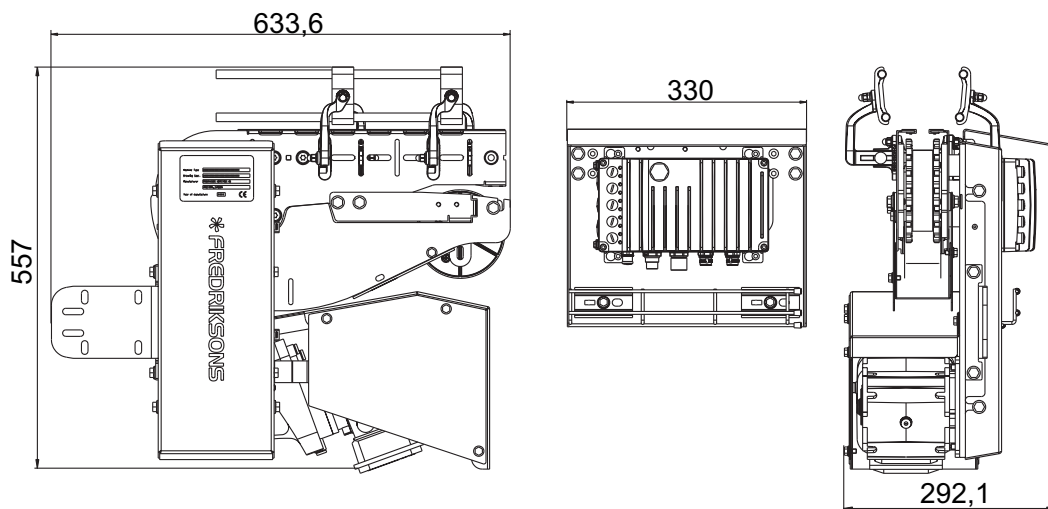

SEW, MOVIMOT EIP/PN

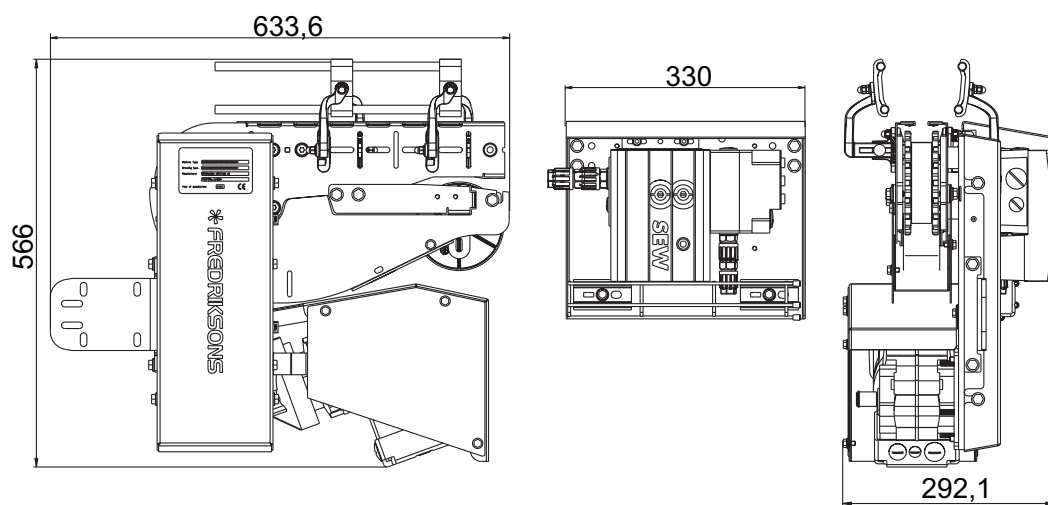

SEW motor

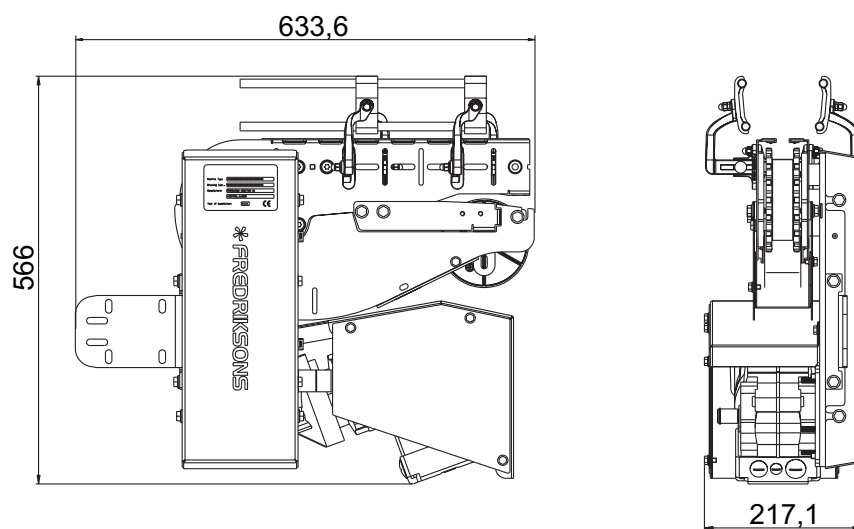

(mm)

Drive & End Unit

Fredriksons Drive & End Unit are available in left and right versions.

Illustration: F243225-1121-04

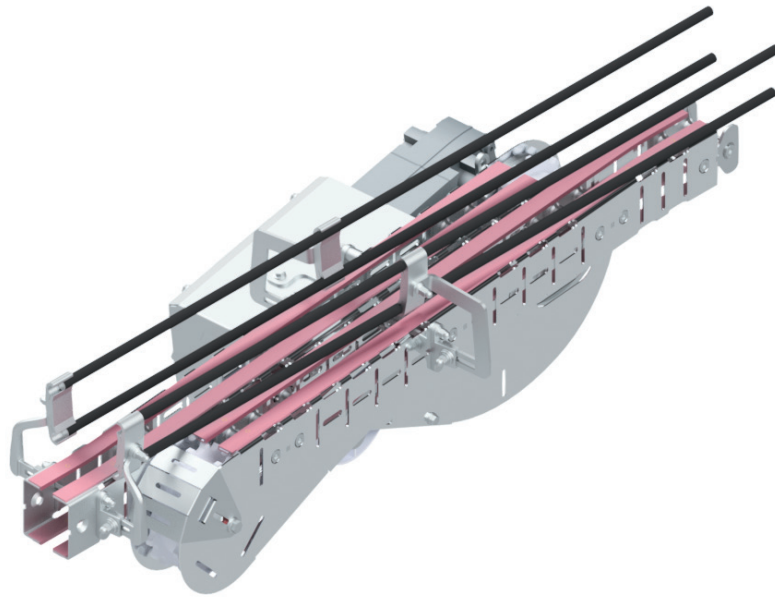

Part number	Variants	Motor	Chain Length m	Weight kg
F243225-1121-01	Left	NORD NORDACON	4	65.5
F243225-1122-01	Right	NORD NORDACON	4	65.5
F243225-1121-02	Left	SEW MOVIMOT EIP	4	35.5
F243225-1122-02	Right	SEW MOVIMOT EIP	4	35.5
F243225-1121-03	Left	SEW MOVIMOT PN	4	35.5
F243225-1122-03	Right	SEW MOVIMOT PN	4	35.5
F243225-1121-04	Left	Standard SEW motor	4	33.6
F243225-1122-04	Right	Standard SEW motor	4	33.6
F243225-1121-05	Left	Standard NORD motor	4	34.3
F243225-1122-05	Right	Standard NORD motor	4	34.3

NORD, NORDACON

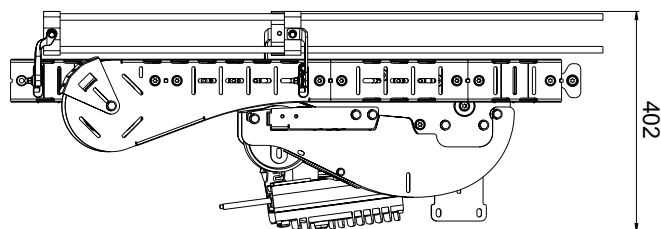
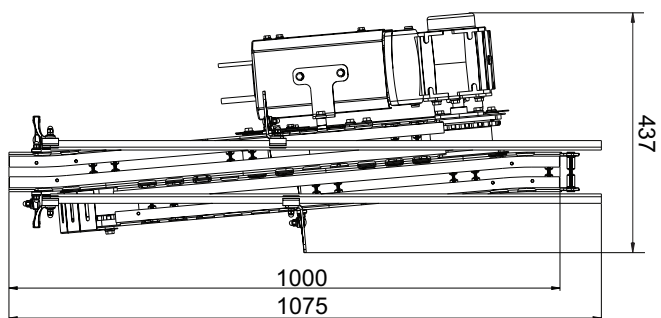

SEW, MOVIMOT EIP/PN

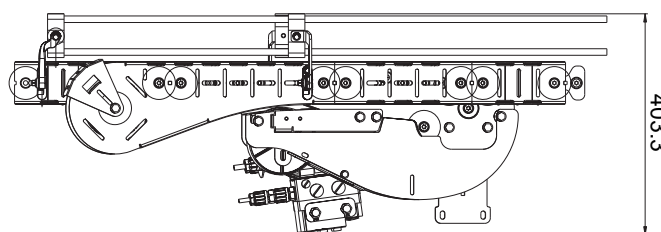
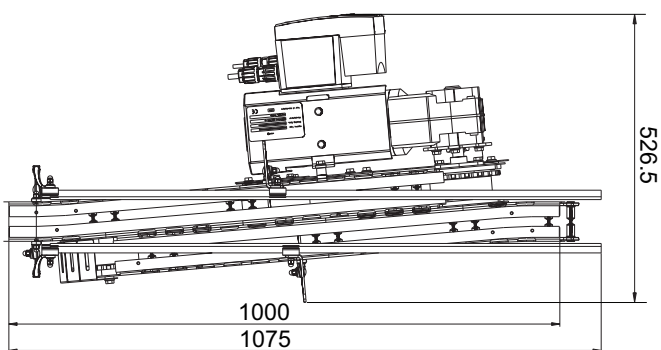

SEW, STANDARD

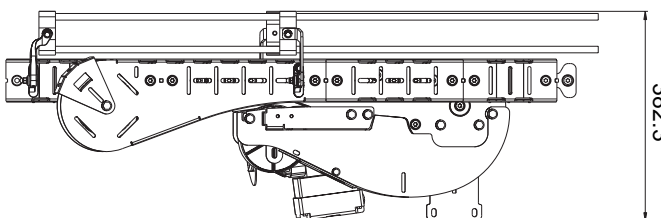
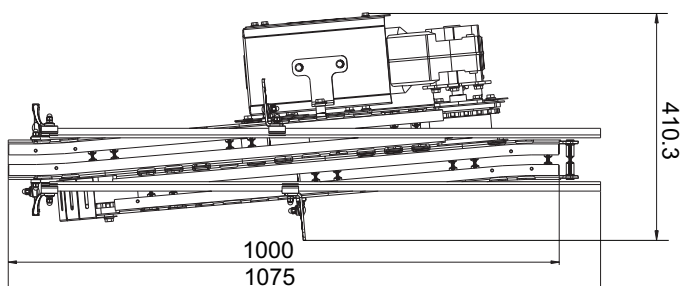

NORD, STANDARD

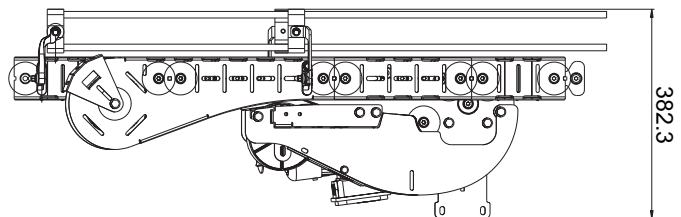
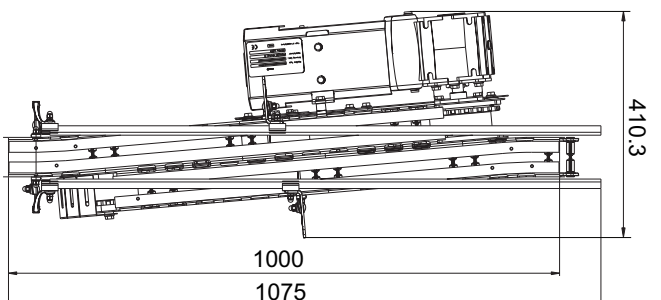

(mm)

Drive & End Unit (Motor on top)

Fredriksons Drive & End Unit are available in left and right versions.

Illustration: F243226-0122-01

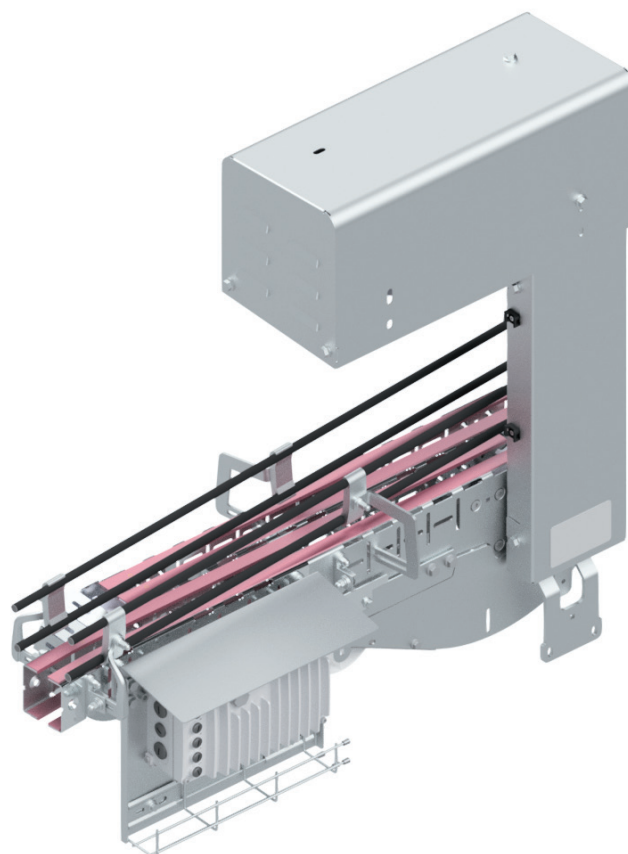

Part number	Variants	Motor	Chain Length m	Weight kg
F243226-0121-01	Left	NORD NORDACON	4	54.6
F243226-0122-01	Right	NORD NORDACON	4	54.6
F243226-0121-02	Left	SEW MOVIMOT EIP	4	54.5
F243226-0122-02	Right	SEW MOVIMOT EIP	4	54.5
F243226-0121-03	Left	SEW MOVIMOT PN	4	54.5
F243226-0122-03	Right	SEW MOVIMOT PN	4	54.5

NORD, NORDACON

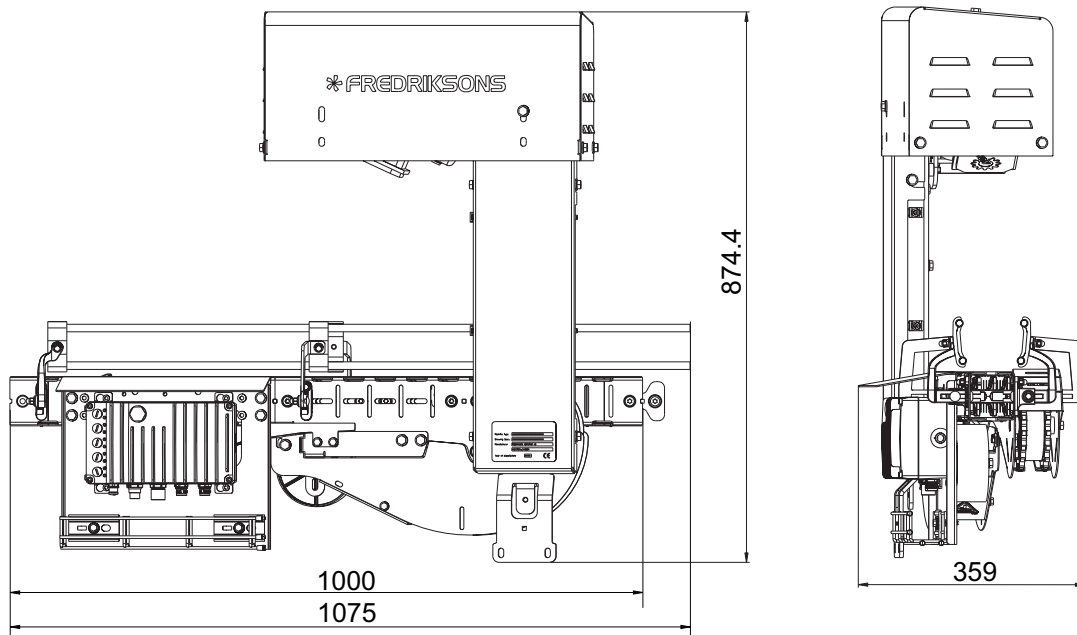

SEW, MOVIMOT EIP/PN

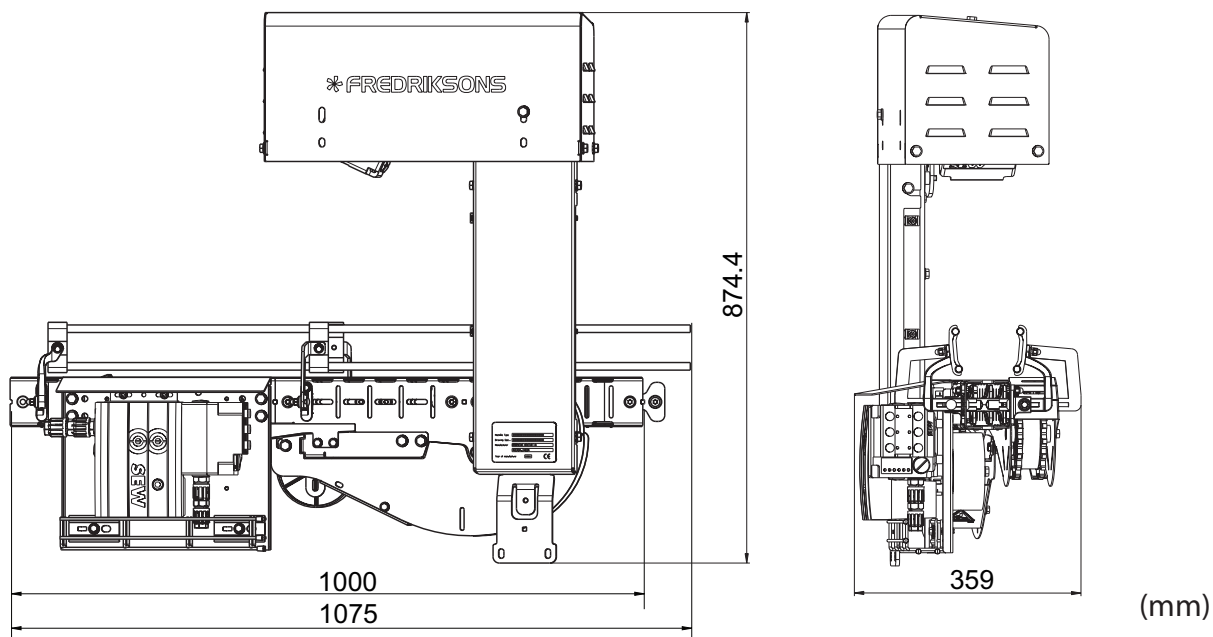

Drive & End Unit (Motor below)

Fredriksons Drive & End Unit are available in left and right versions.

Illustration: F243227-0121-01

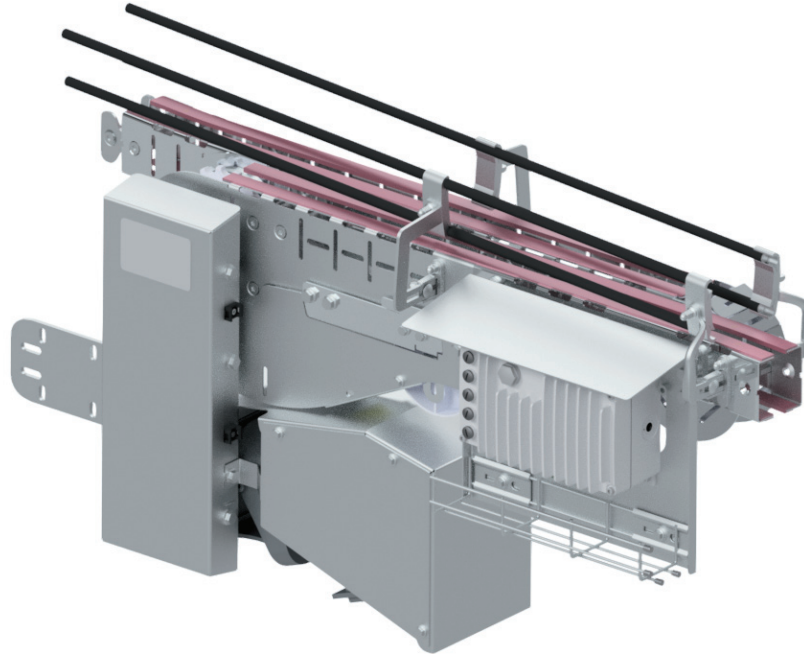

Part number	Variants	Motor	Chain Length m	Weight kg
F243227-0121-01	Left	NORD NORDACON	4	49.2
F243227-0122-01	Right	NORD NORDACON	4	49.2
F243227-0121-02	Left	SEW MOVIMOT EIP	4	48.7
F243227-0122-02	Right	SEW MOVIMOT EIP	4	48.7
F243227-0121-03	Left	SEW MOVIMOT PN	4	48.7
F243227-0122-03	Right	SEW MOVIMOT PN	4	48.7

NORD, NORDACON

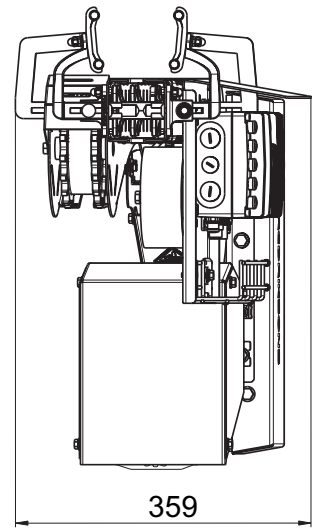
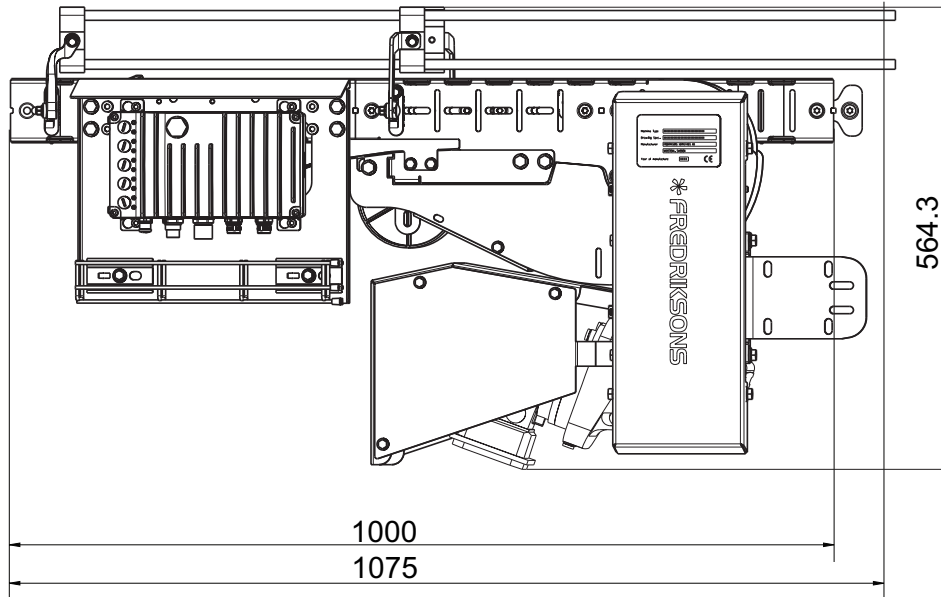

SEW, MOVIMOT EIP/PN

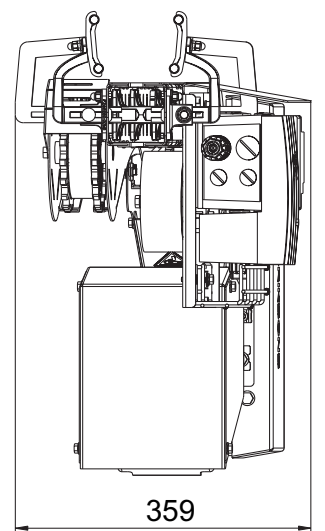
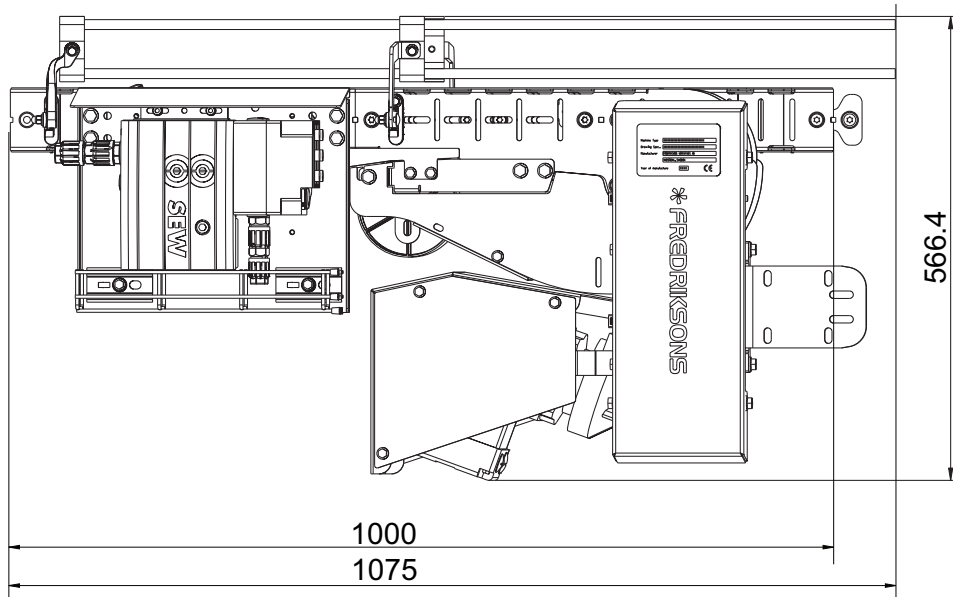

(mm)

Switch 1-2

Fredriksons Switch 1-2

Illustration: F241037-1121-01

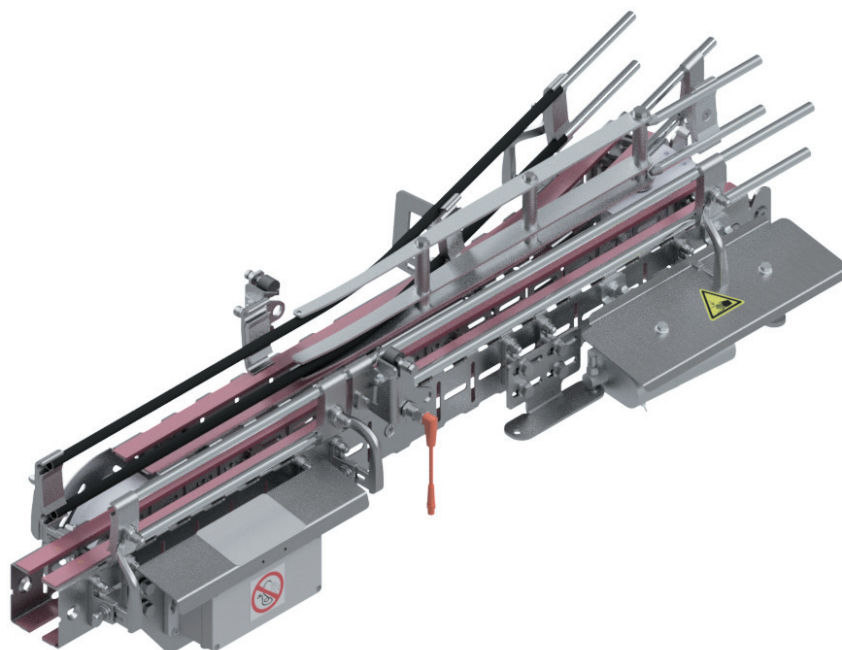

Part number	Variants	Chain Length m	Weight kg
F240650-1121-00	Manual/Left	4	16
F240650-1122-00	Manual/Right	4	16
F241037-1121-01	Automatic/Left	4	23
F241037-1122-01	Automatic/Right	4	23

Manual

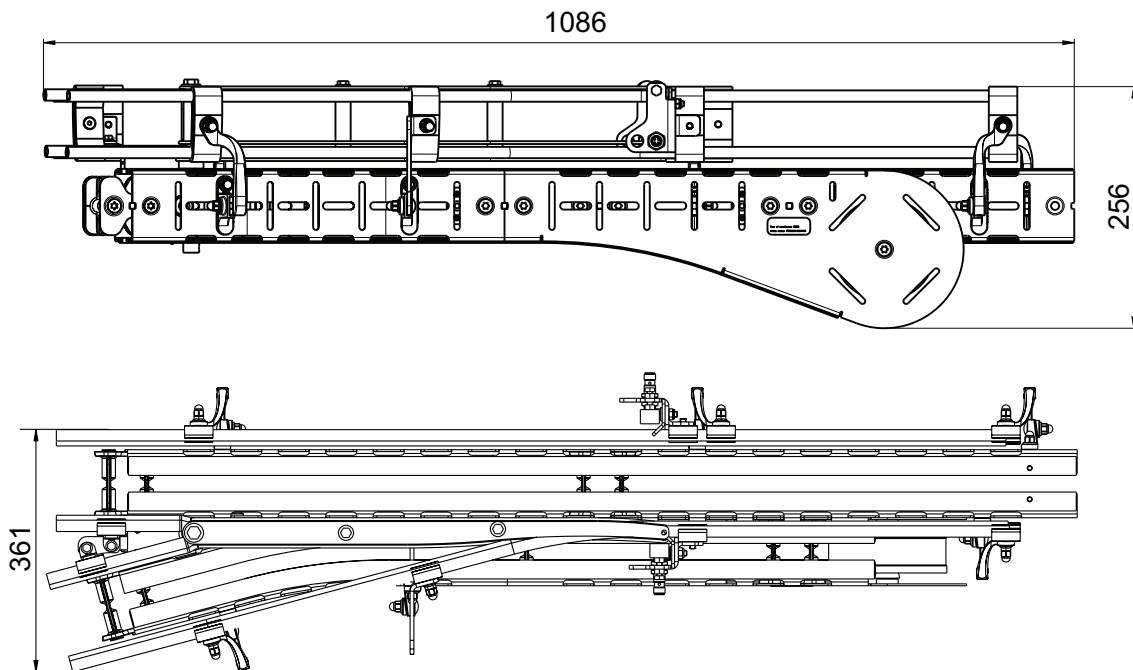

Automatic

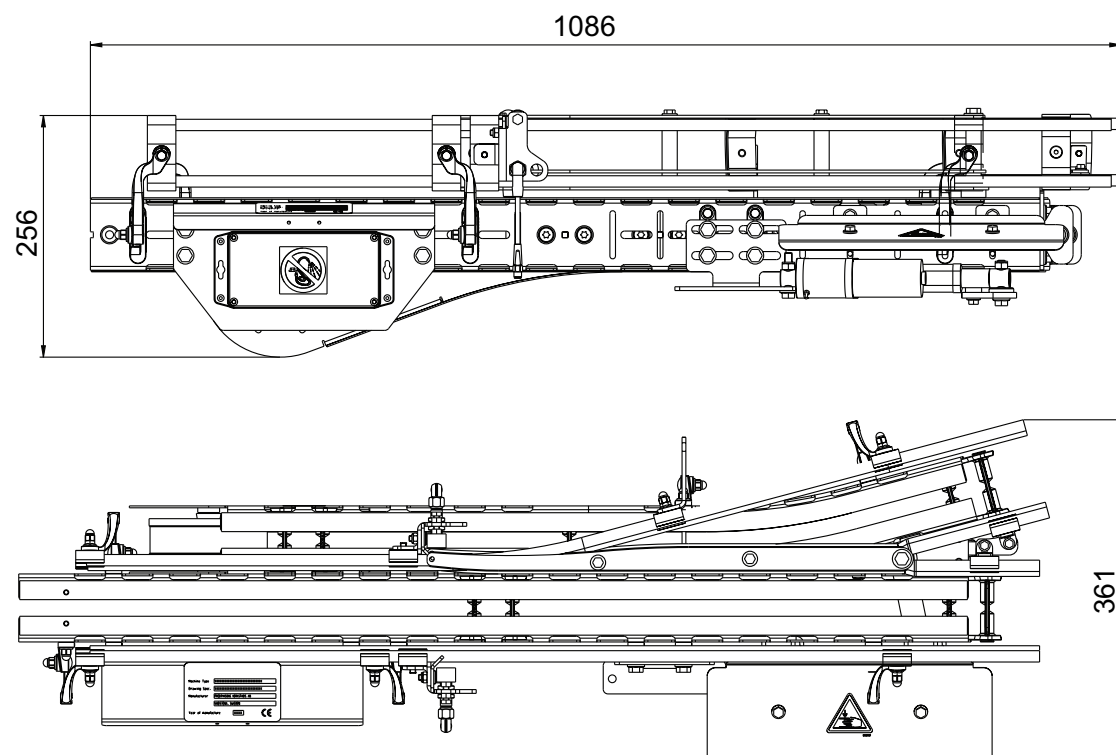

(mm)

Switch 2-1

Fredriksons Switch 2-1

Illustration: F243228-1121-01

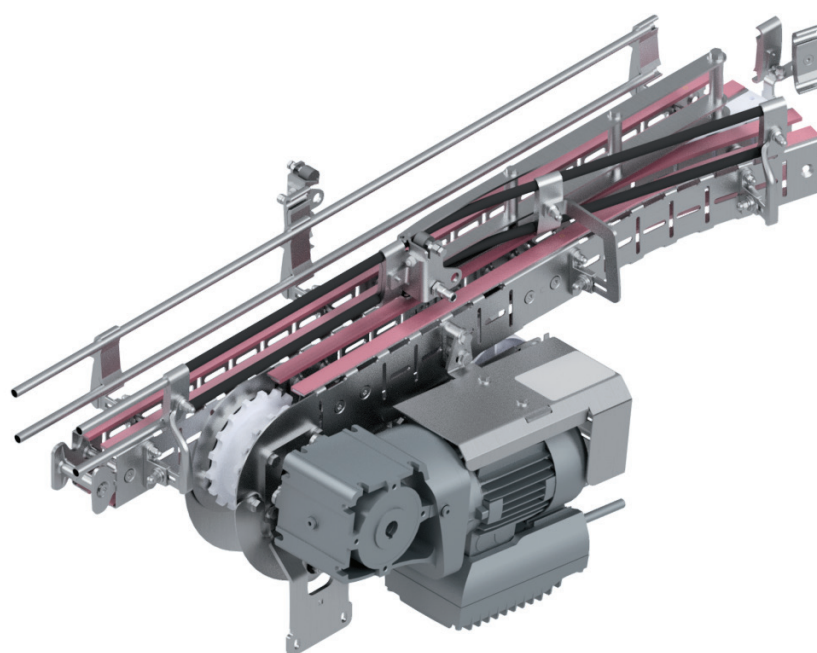

Part number	Variants	Motor	Chain Length m	Weight kg
F243228-1121-01	Left	NORD NORDACON	4	34.7
F243228-1122-01	Right	NORD NORDACON	4	34.7
F243228-1121-02	Left	SEW MOVIMOT EIP	4	36.9
F243228-1122-02	Right	SEW MOVIMOT EIP	4	36.9
F243228-1121-03	Left	SEW MOVIMOT PN	4	36.9
F243228-1122-03	Right	SEW MOVIMOT PN	4	36.9
F243228-1121-04	Left	Standard SEW motor	4	35.0
F243228-1122-04	Right	Standard SEW motor	4	35.0
F243228-1121-05	Left	Standard NORD motor	4	35.7
F243228-1122-05	Right	Standard NORD motor	4	35.7

NORD, NORDACON

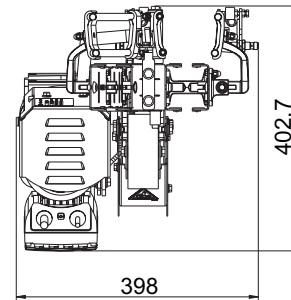
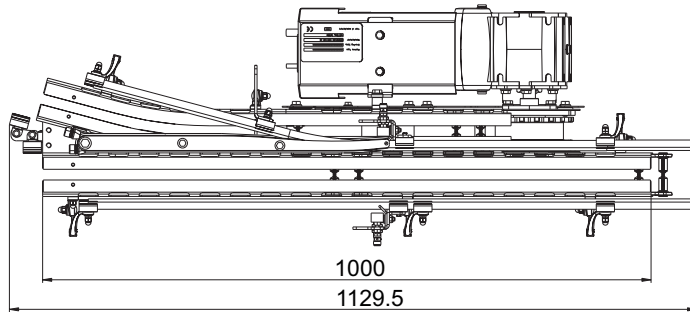

SEW, MOVIMOT EIP/PN

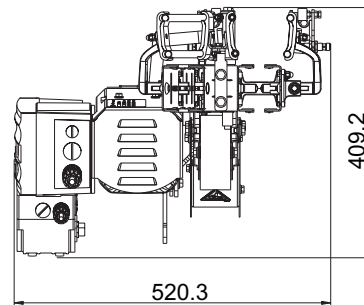
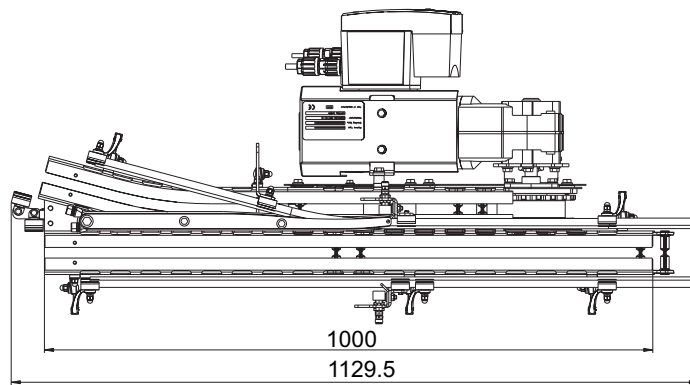

SEW motor

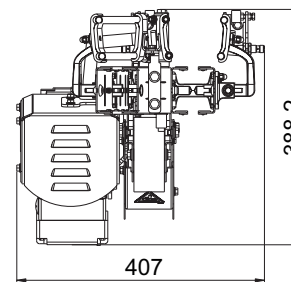
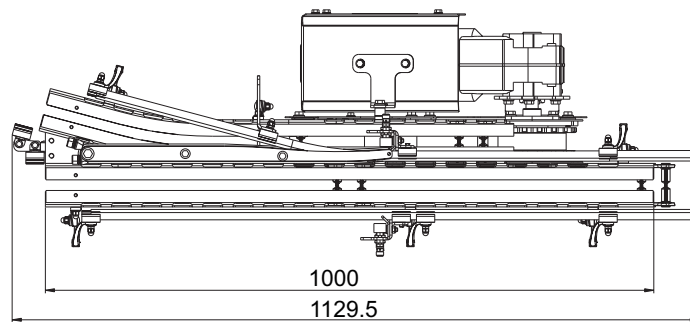

NORD motor

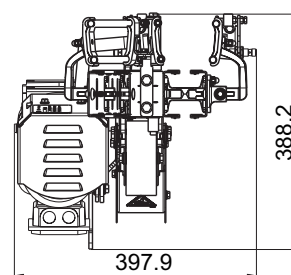
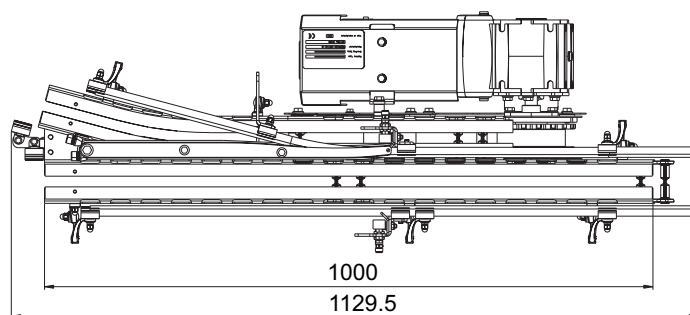

(mm)

Switch 2-1 (Motor On Top)

Fredriksons Switch 2-1 are available in left and right versions.

Illustration: F243228-1123-01

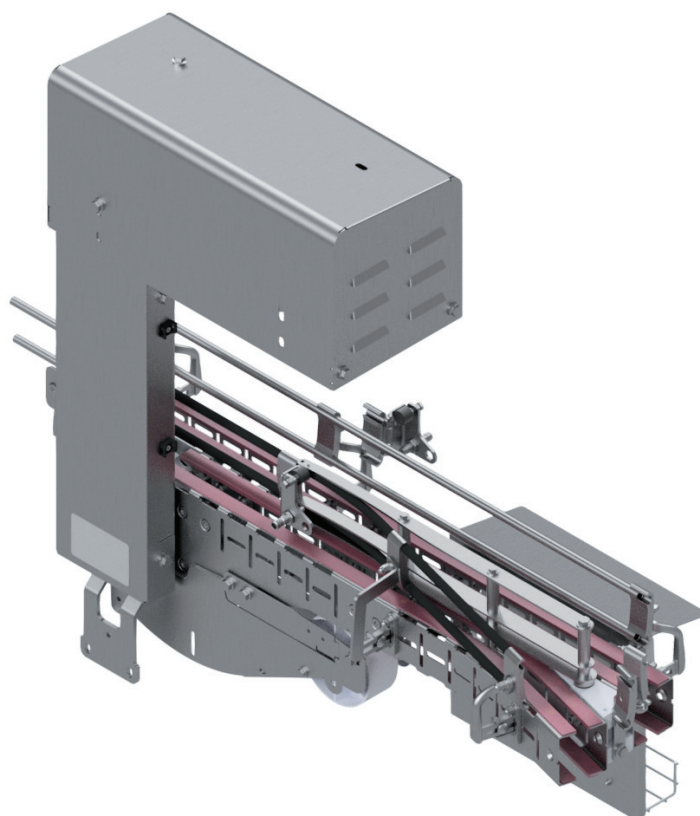

Part number	Variants	Motor	Chain Length m	Weight kg
F243228-1123-01	Left	NORD NORDACON	4	56.0
F243228-1124-01	Right	NORD NORDACON	4	56.0
F243228-1123-02	Left	SEW MOVIMOT EIP	4	55.8
F243228-1124-02	Right	SEW MOVIMOT EIP	4	55.8
F243228-1123-03	Left	SEW MOVIMOT PN	4	55.8
F243228-1124-03	Right	SEW MOVIMOT PN	4	55.8

NORD, NORDACON

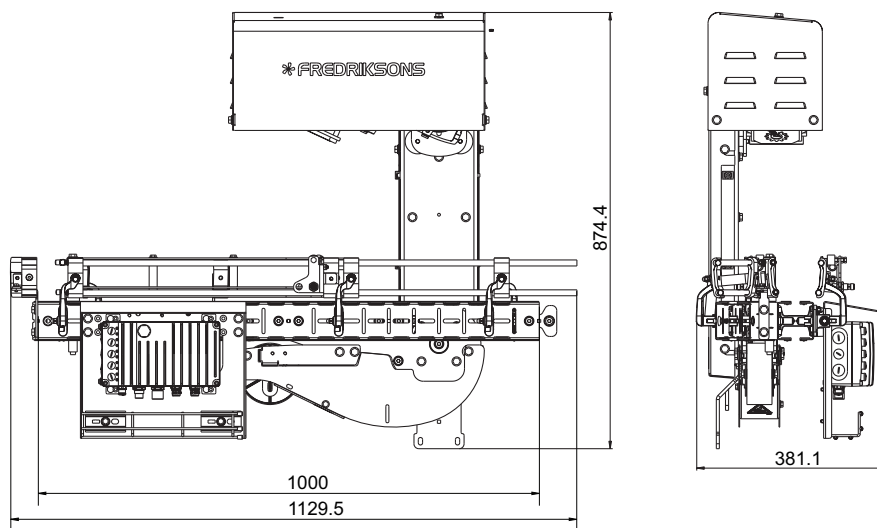

SEW, MOVIMOT EIP

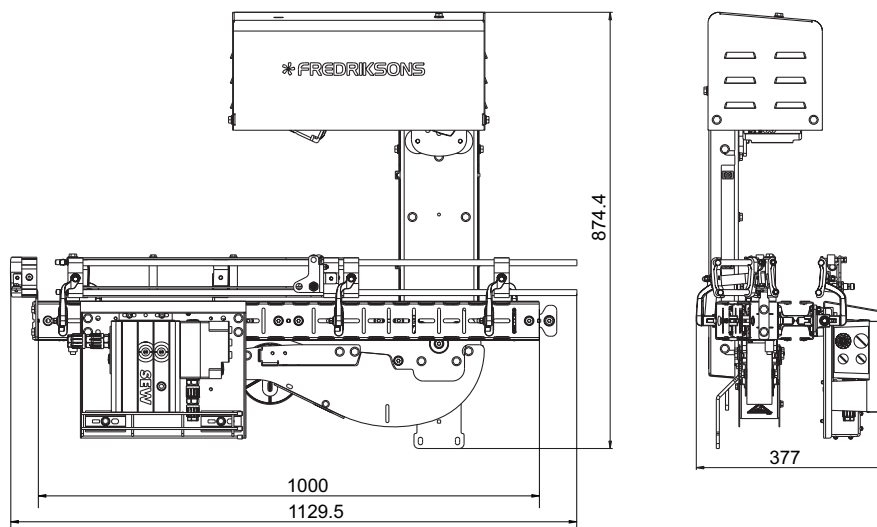

SEW, MOVIMOT PN

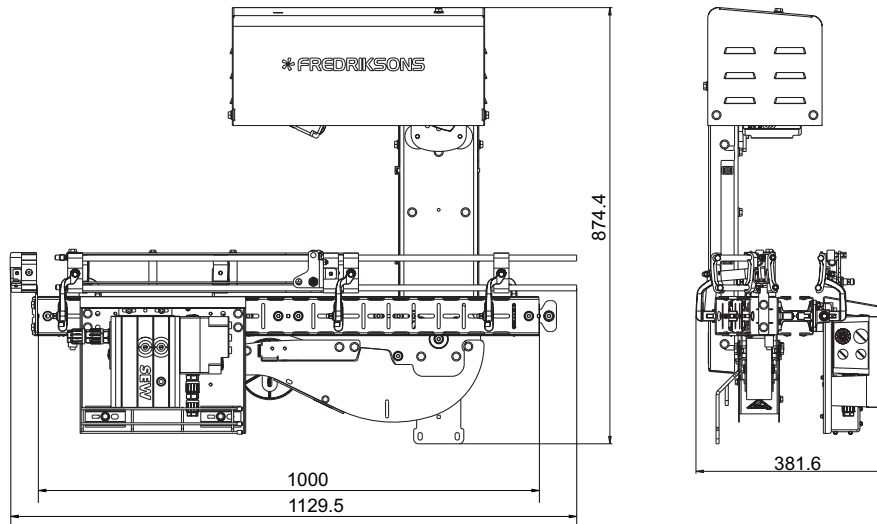

(mm)

Switch 2-1 (Motor Below)

Fredriksons Switch 2-1 are available in left and right versions.

Illustration: F243228-1125-01

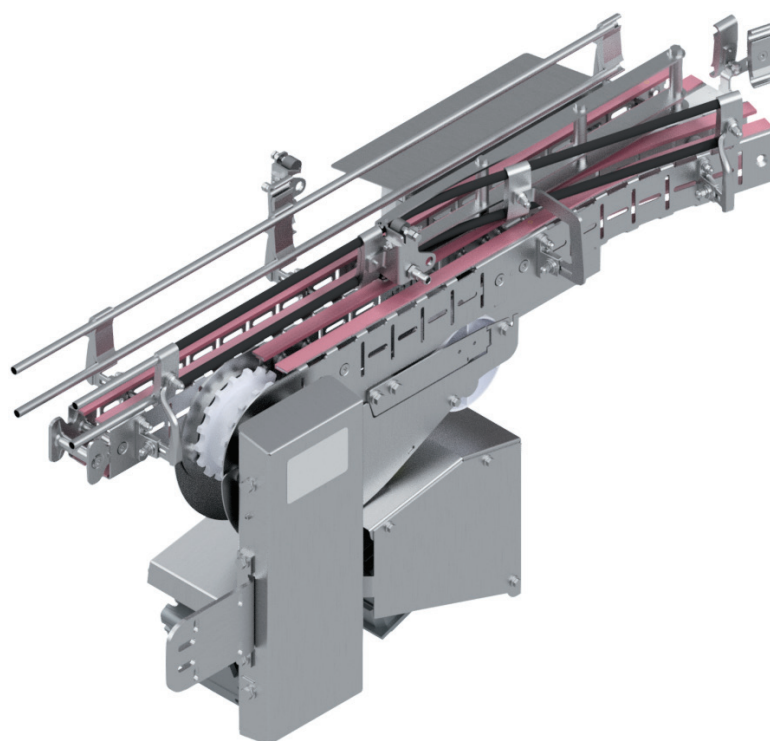

Part number	Variants	Motor	Chain Length m	Weight kg
F243228-1125-01	Left	NORD NORDACON	4	50.6
F243228-1126-01	Right	NORD NORDACON	4	50.6
F243228-1125-02	Left	SEW MOVIMOT EIP	4	50.0
F243228-1126-02	Right	SEW MOVIMOT EIP	4	50.0
F243228-1125-03	Left	SEW MOVIMOT PN	4	50.0
F243228-1126-03	Right	SEW MOVIMOT PN	4	50.0

NORD, NORDACON

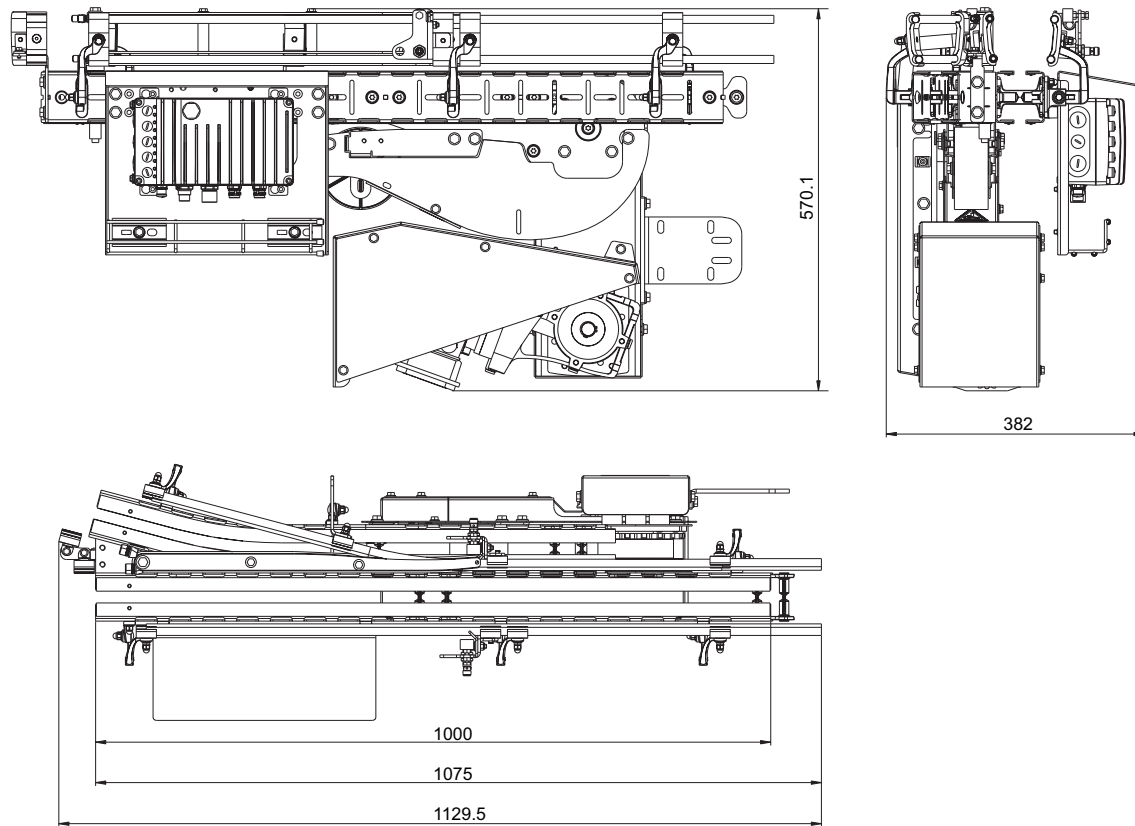

SEW, MOVIMOT EIP/PN

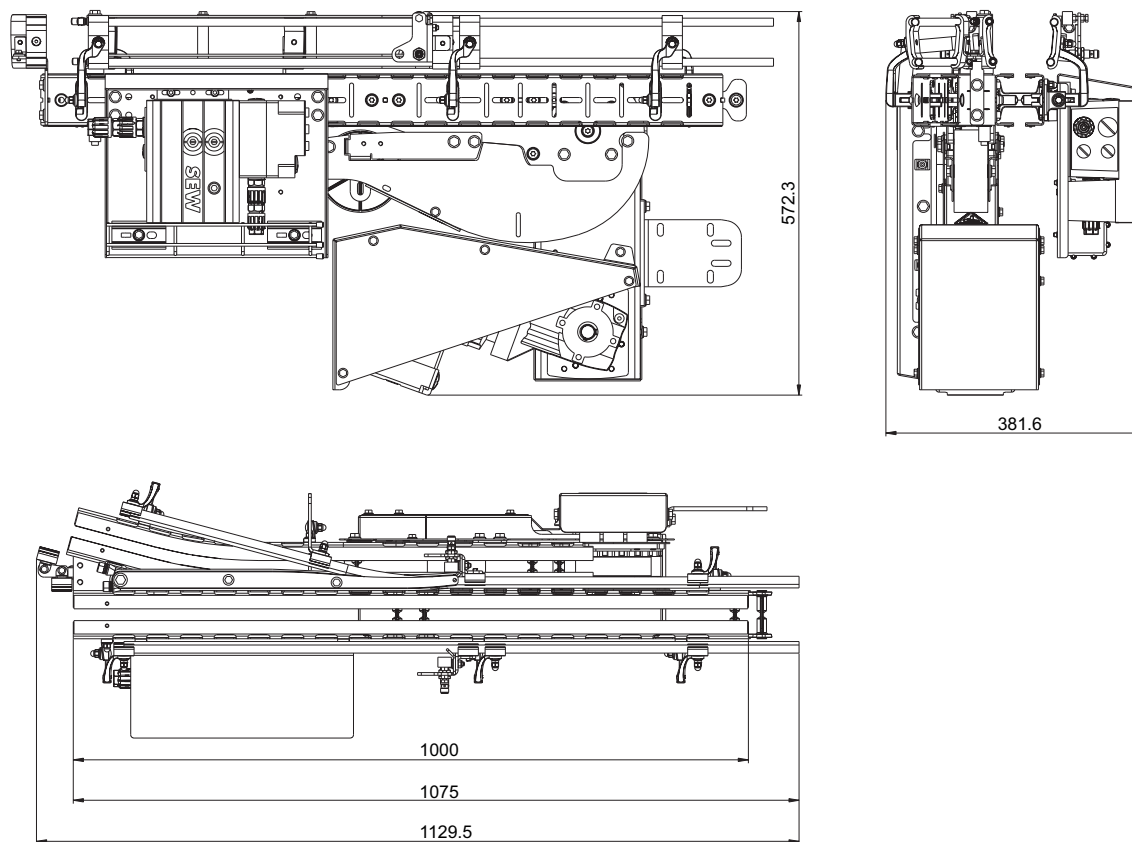

(mm)

Belt Brake

Fredriksons Belt Brake

Illustration: F233901-105

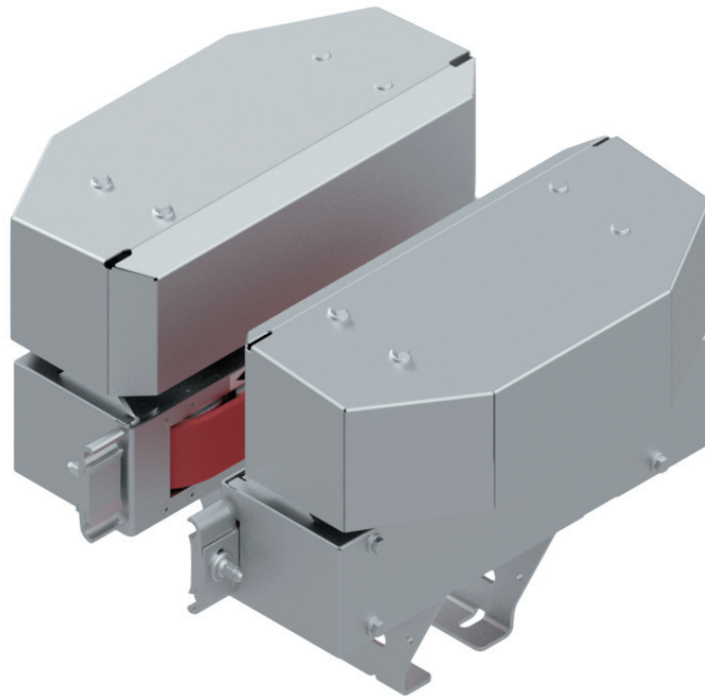

Part number	Motor	Weight kg
F233901-105	SEW Geared Motor	33.3
F241955-109	Frequency Converter CPL Double Motors NORDACON	7.1

(optional add-on for motor control)

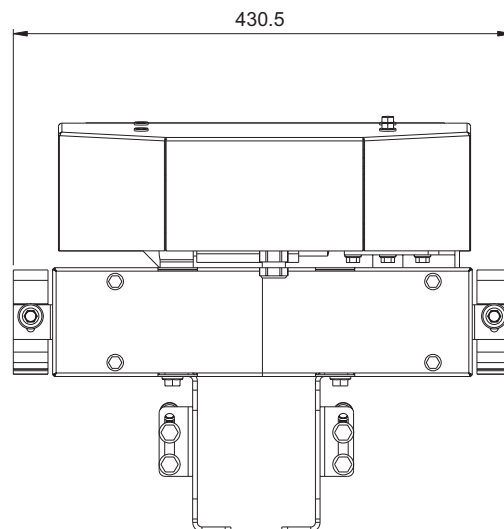
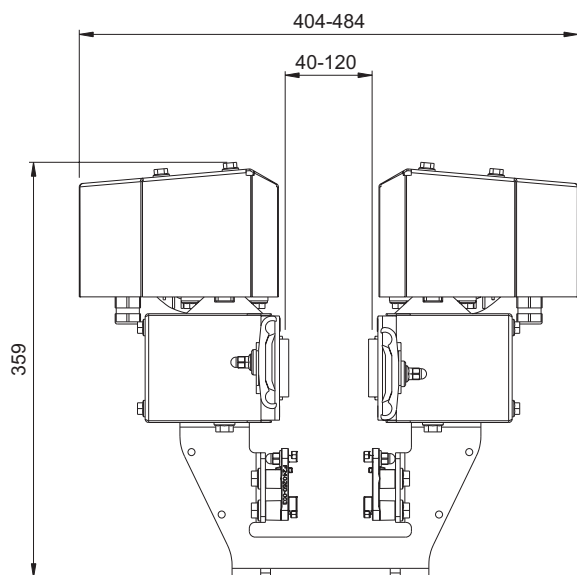

(mm)

Hose Brake

Fredriksons Hose Brake

Illustration: F241700-101

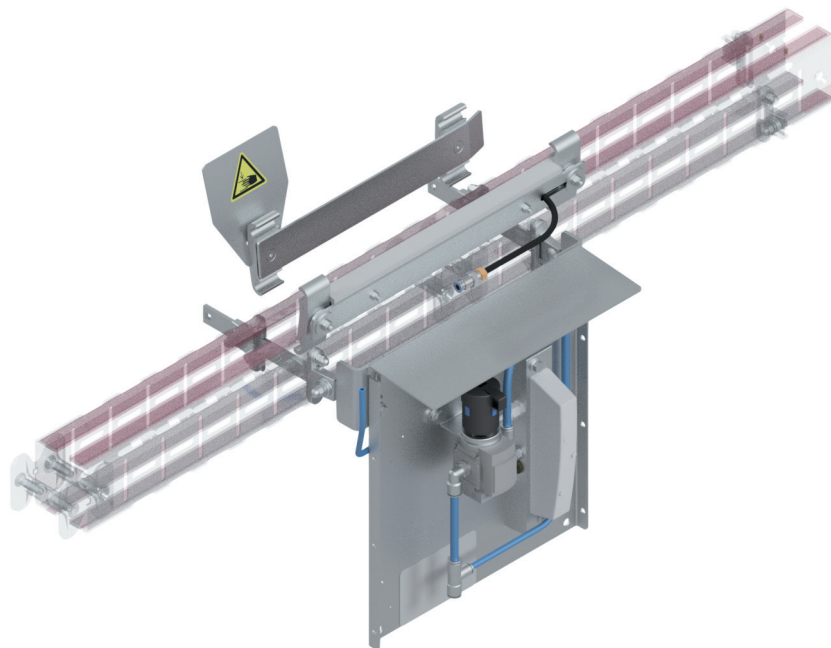

Part number	Variants	Weight kg
F241700-101	with sensor	13.4
F241700-102	without sensor	9.8
F241700-0103	without sensor	8.0

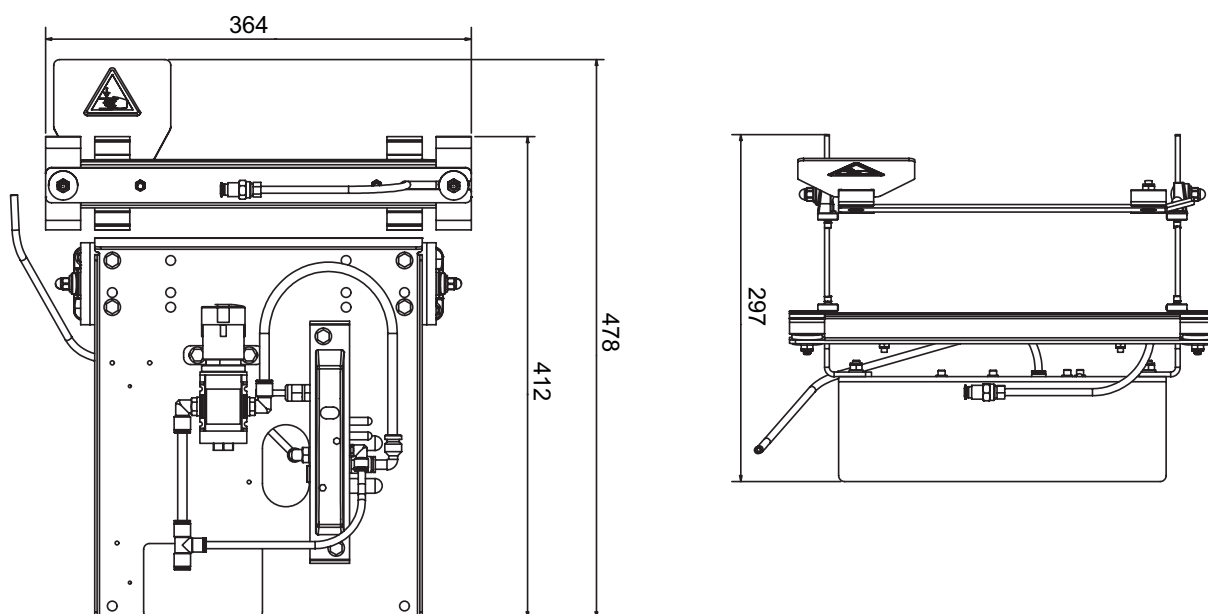

(mm)

Package Trap (Newton)

Fredriksons Package trap is used to catch up fallen packages.

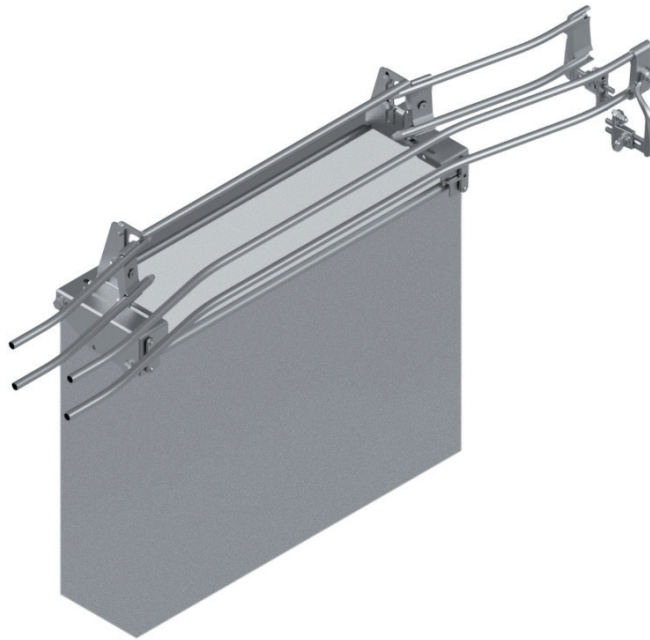

Part number	Railing width mm	Weight kg
F240755-0020-00	40-120	4

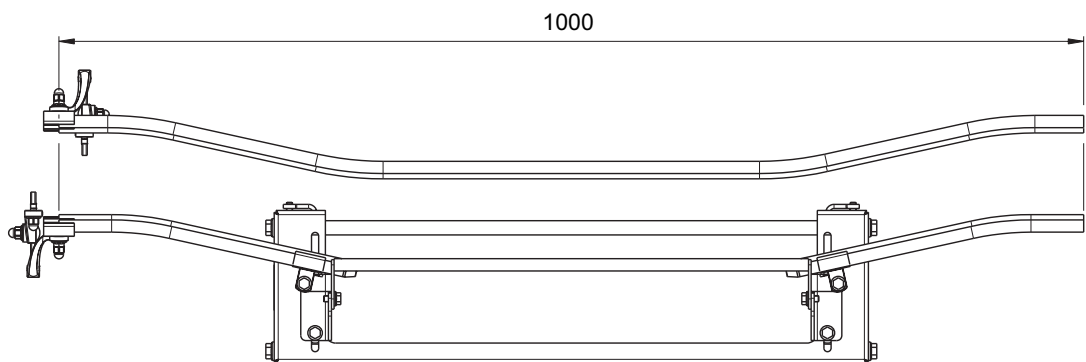

(mm)

Package Trap (Blow)

Fredriksons Package Trap (Blow) uses pneumatic air nozzle to blow out packages that have been rejected. A net below catches these packages.

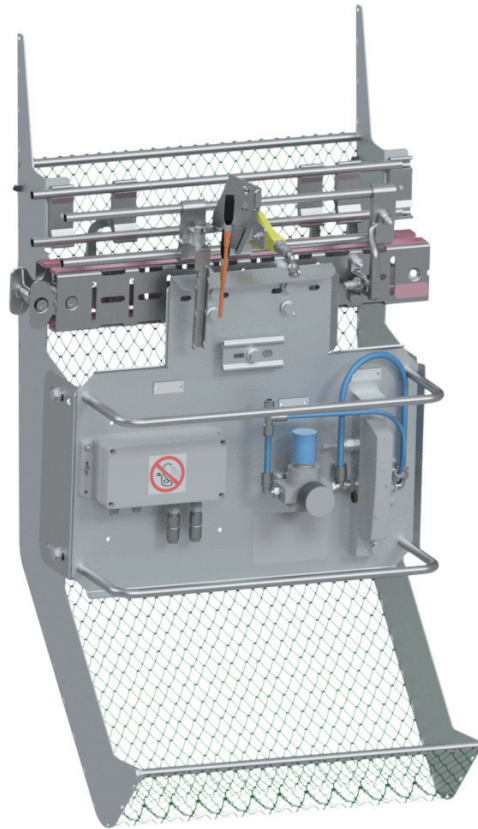

Part number	Railing width mm	Air Pressure	Weight kg
F242480-103	40-120	6 bar	22.3

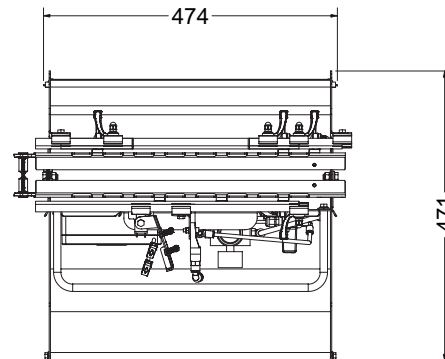
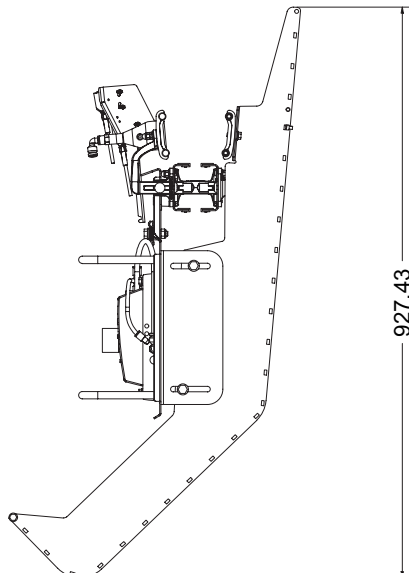

(mm)

Package Trap (Push)

Fredriksons Package Trap (Push) uses a pneumatic pusher to push out packages that have been rejected. A net below catches these packages.

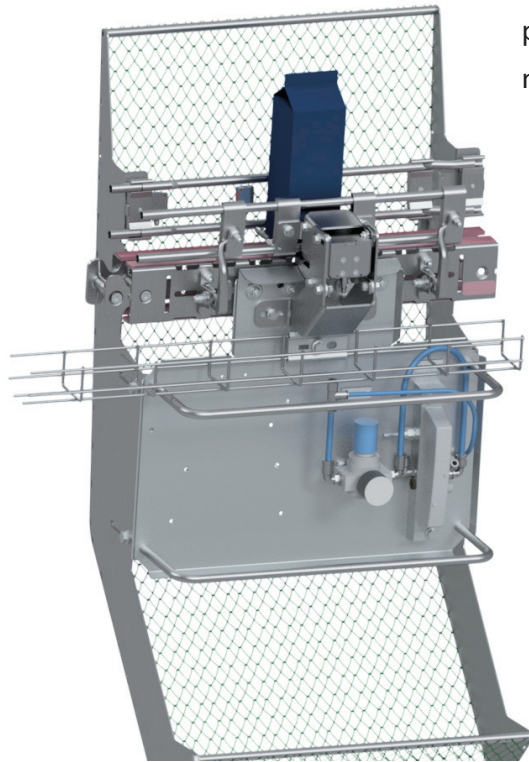

Part number	Railing width mm	Air Pressure	Weight kg
F241495-102	40-120	4 bar	28

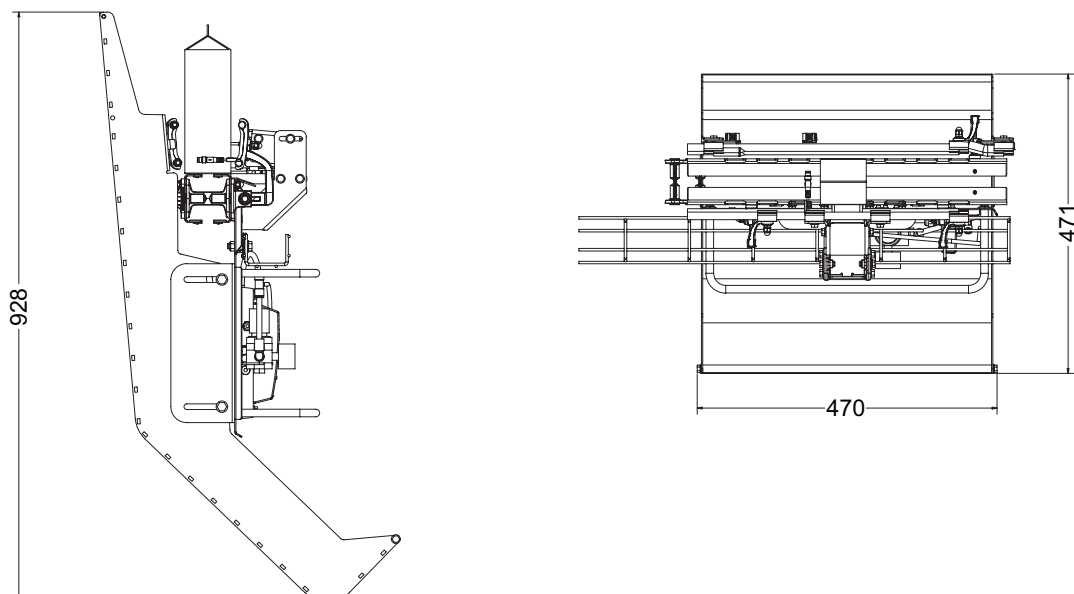

(mm)

Chains

CS 70 is a new developed improved plastic chain according to safety regulations standard BS EN619.

For more information regarding our range of plastic chains, please check our Chains catalogue

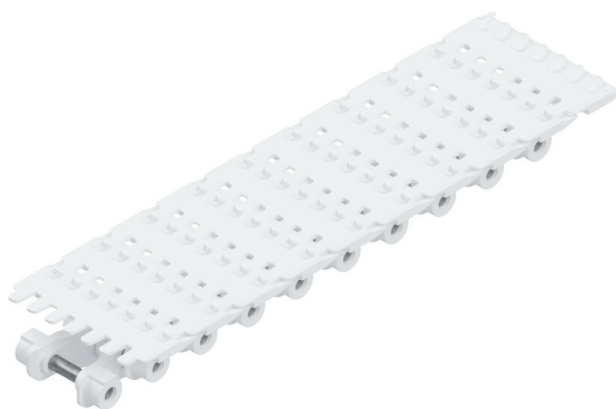

Part number	Materials	Length (L)	Weight	Width	Volume
F240793-101	Delrin	10 m per box	14 kg /10 m	70 mm	20 dm ³ /10 m
F240793-102	Hostaform	10 m per box	14 kg /10 m	70 mm	20 dm ³ /10 m

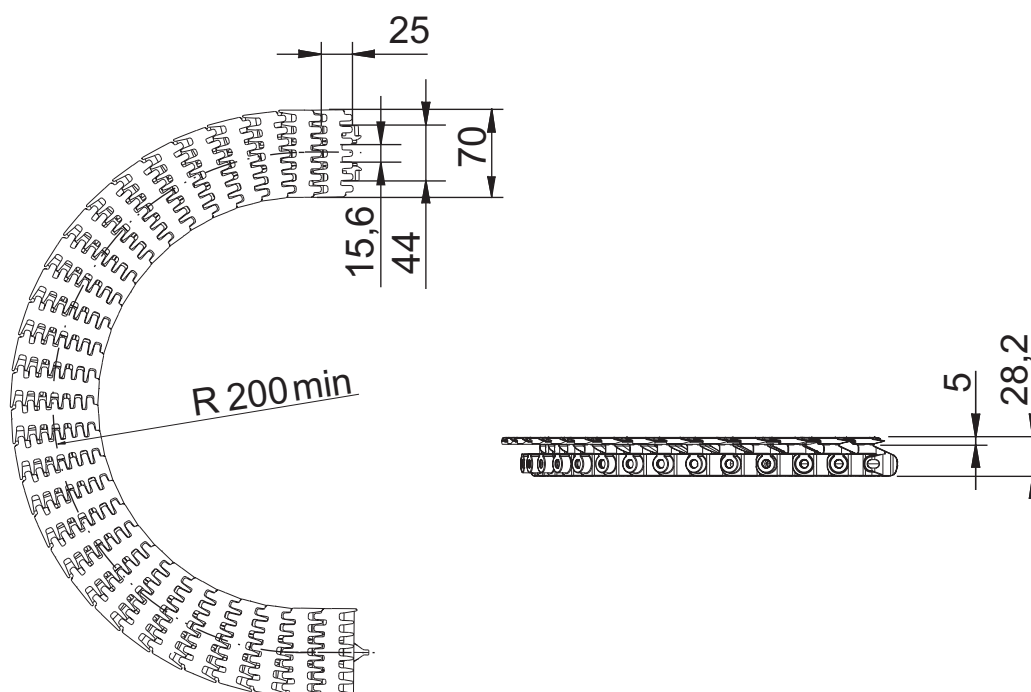

Chain Removal Section

Fredriksons Chain Removal Section is used for better accessibility on the chain.

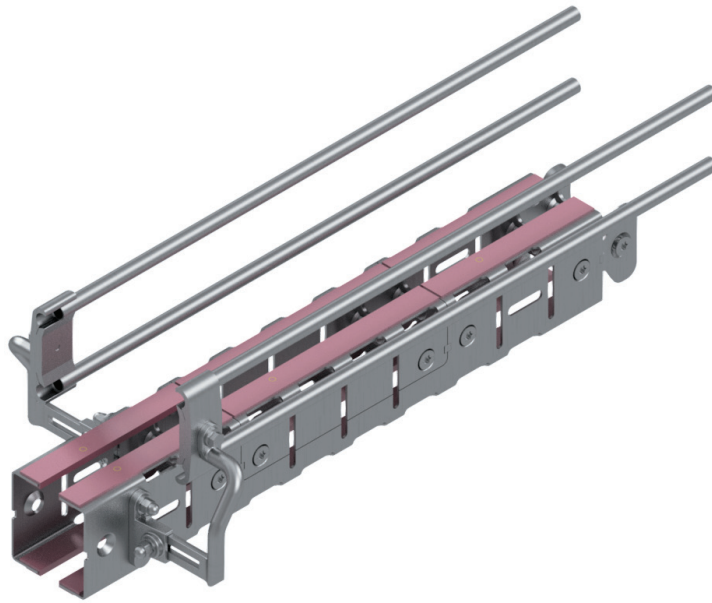

Part number	Railing width mm	Chain Length m	Weight kg
F240061-1120-00	40-120	1.0	4.3

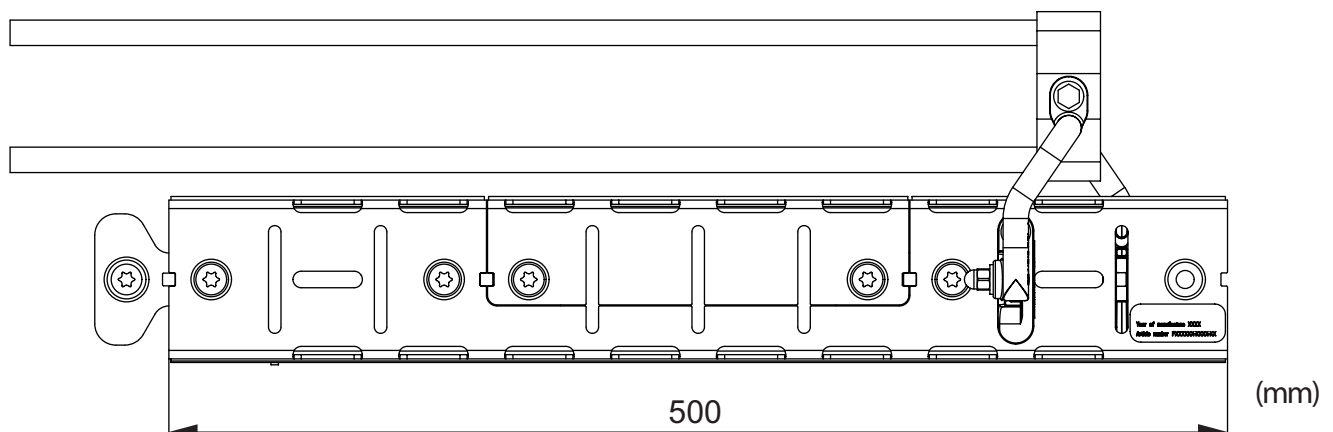

Telescopic Conveyor

Fredriksons Telescopic conveyor is adjustable between 350-490 mm.

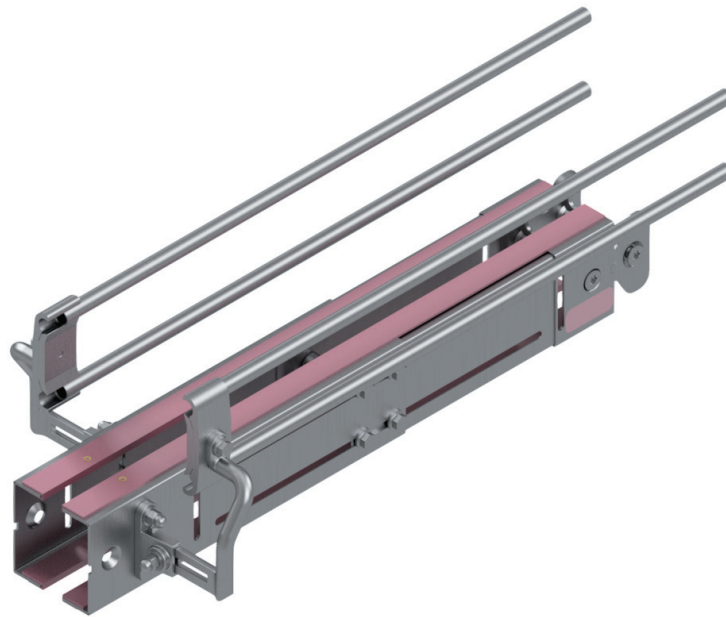

Part number	Railing width mm	Chain Length m	Weight kg
F240220-1120-00	40-120	0.7-1	3.3

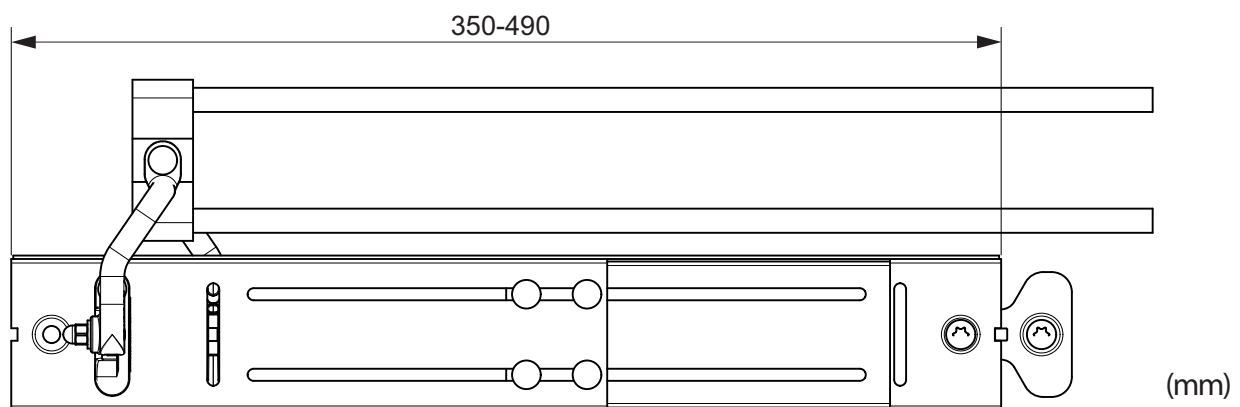

Junction Kit

Fredriksons Junction kit is used when joining cut straight conveyors.

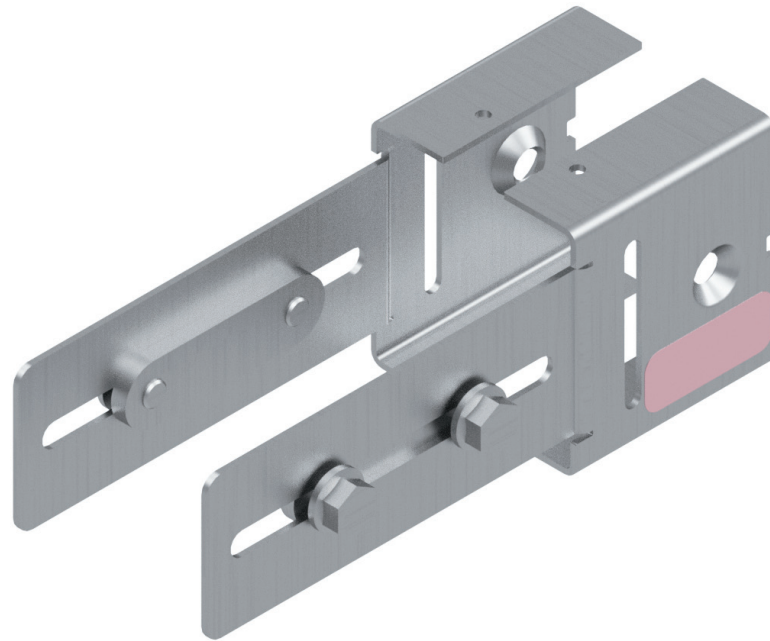

Part number	Weight kg
F240064-0010-00	0.6

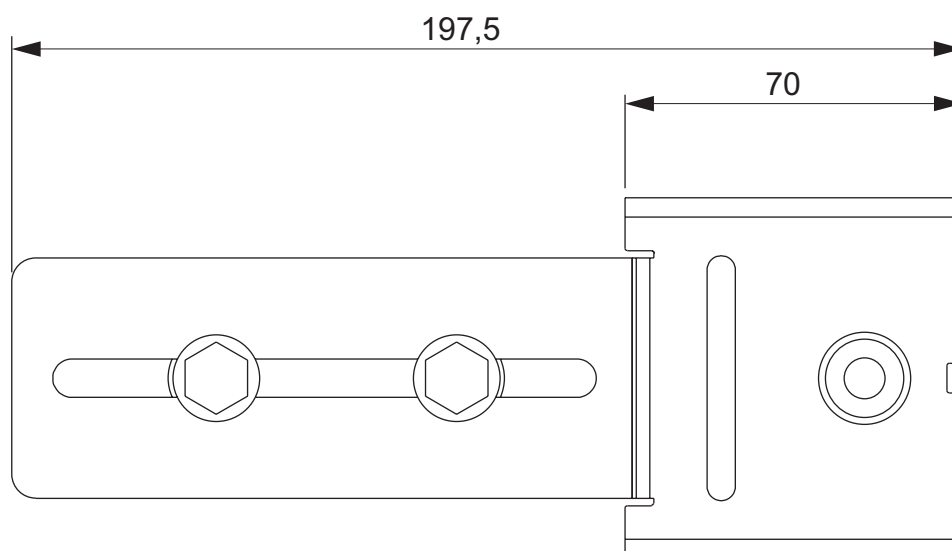

(mm)

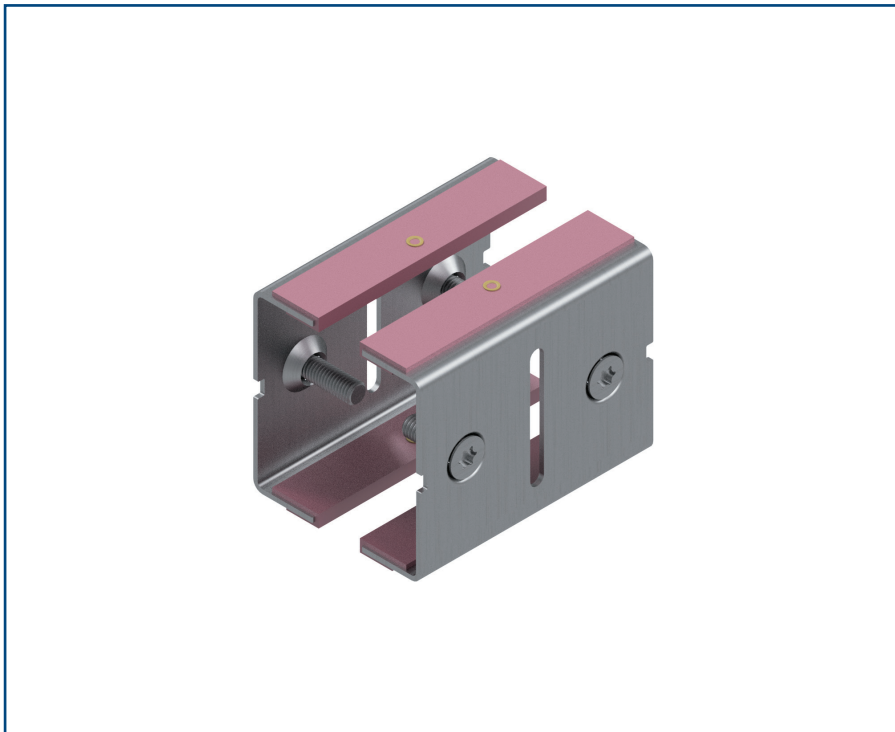

Junction Kit - Curve

Fredriksons Junction kit is used between curves.

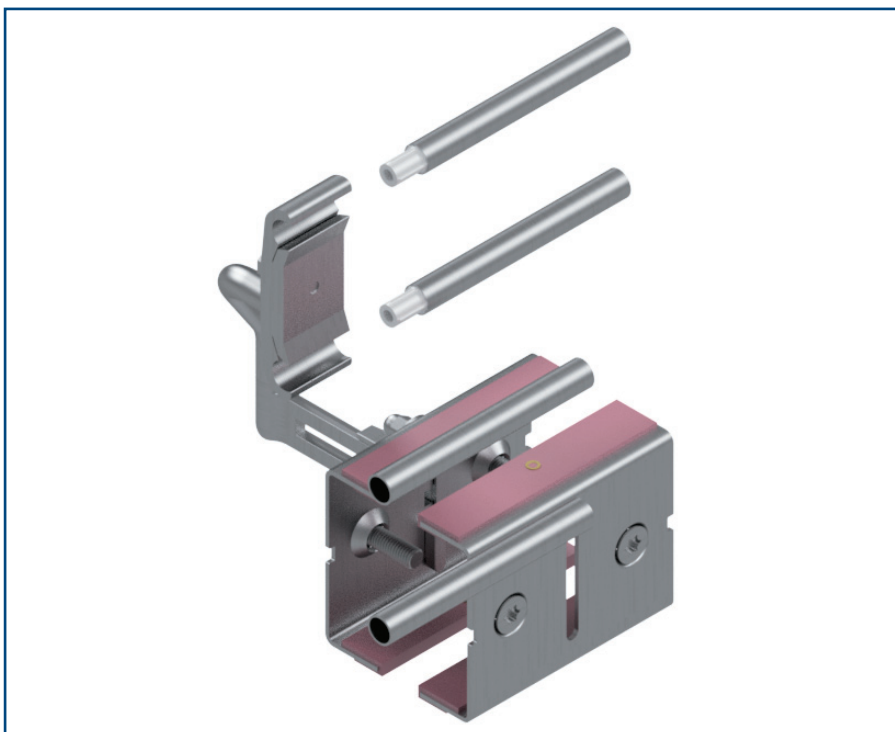

Junction Kit - Wheel Curve

Fredriksons Junction kit is used between Wheel curves.

Part number	Variant	Length mm	Weight kg
F240985-102	Curve-Curve	100	0.4
F240985-103	Wheel-Curve	100	1.0

Sensor Kit

Fredriksons Sensor kit has a range between 35-140mm..



Part number	Sensor Type	Sensor
F242858-0101	Photoelectric	SICK

* Contact our sales team for a complete catalogue of available sensors

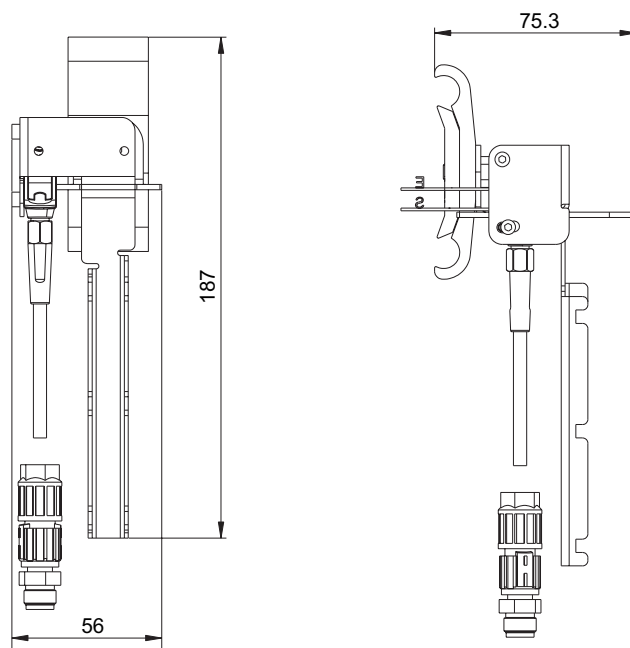

(mm)

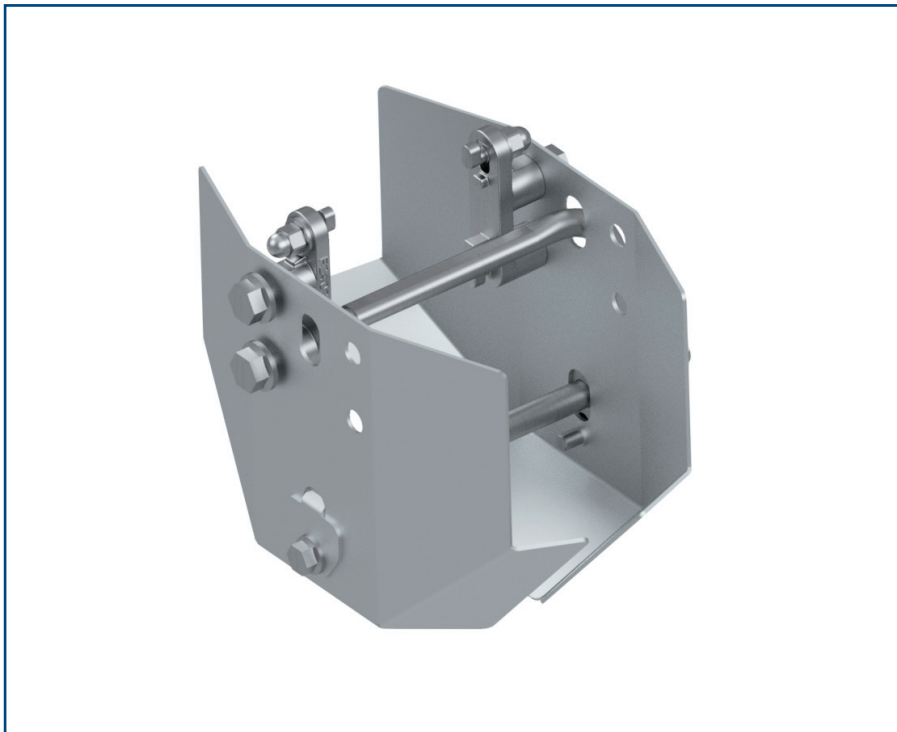

Washing Unit (No Drain)

Washing unit is used with Fredriksons Straight Conveyor and Drip Tray.

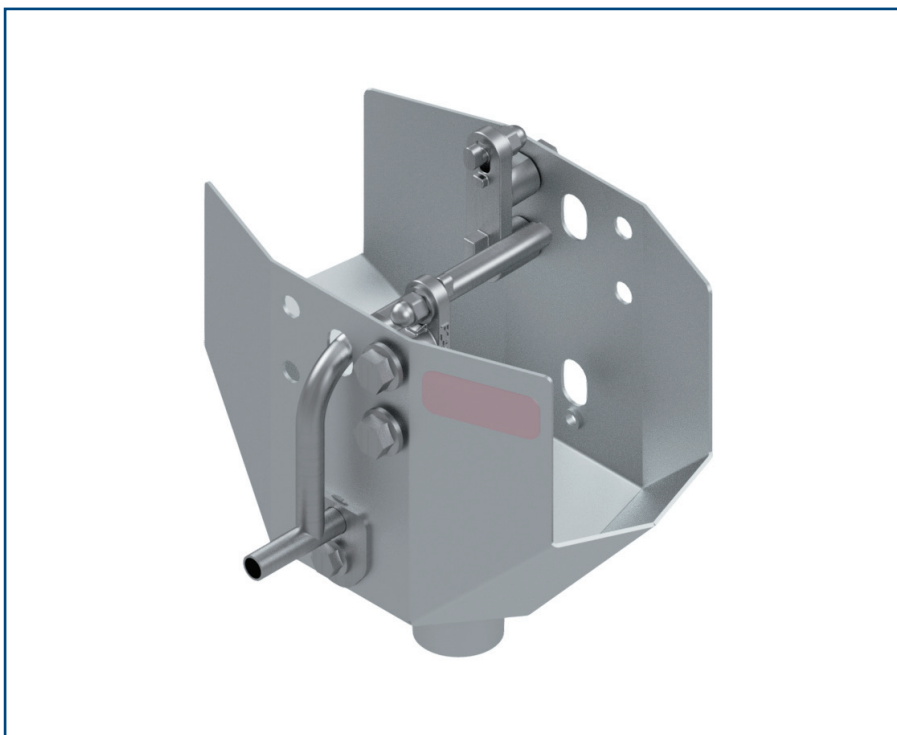

Washing Unit (With Drain)

Washing unit is used with Fredriksons Straight Conveyor.

Part number	Type	Weight kg
F240665-0100-01	Straight Conveyor (No Drain)	1.0
F240665-0100-02	Straight Conveyor (With Drain)	1.1

F241637-003

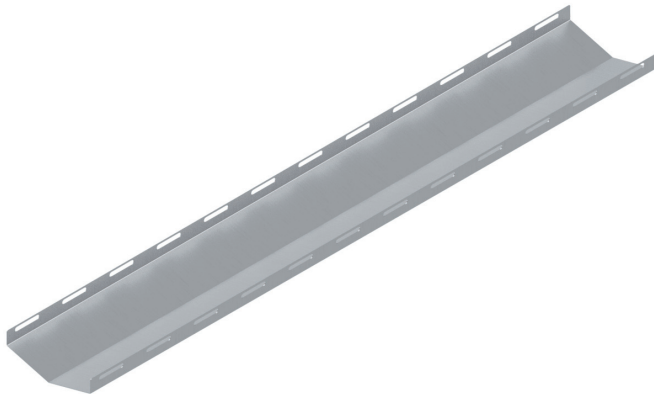

Drip Tray (Straight Conveyor)

This Fredriksons Drip Tray is used together with Fredriksons CS70 Straight Conveyor.

Part num-ber	Type	Weight kg
F241637-003	For Straight Conveyor (1m)	4.9
F241637-004	For Straight Conveyor (3m)	1.7

F241637-009



Drip Tray (Glide Curve)

This Fredriksons Drip Tray is used together with Fredriksons CS70 Glide Curve.

Part num-ber	Type	Weight kg
F241637-005	For Glide Curve (15°)	1.4
F241637-006	For Glide Curve (30°)	1.8
F241637-007	For Glide Curve (45°)	2.1
F241637-008	For Glide Curve (75°)	2.9
F241637-009	For Glide Curve (90°)	3.3

F241637-101

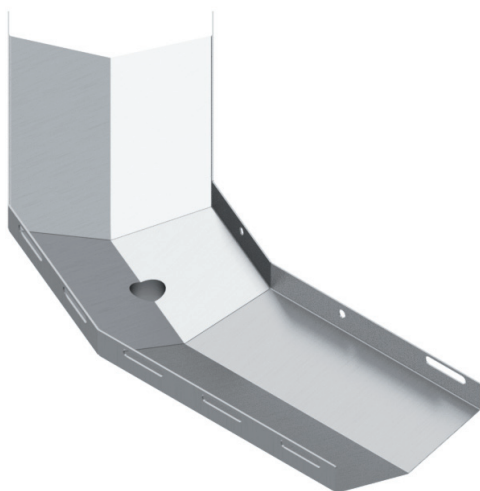

Drip Tray (Wheel Curve with Drain)

This Fredriksons Drip Tray is used together with Fredriksons CS70 Glide Curve.

Part num-ber	Type	Weight kg
F241637-101	For Wheel Curve (45°)	1.7
F241637-104	For Wheel Curve (75°)	2.0
F241637-107	For Wheel Curve (90°)	2.1
F241637-113	For Wheel Curve (180°)	3.8
F241637-114	For Wheel Curve (180°)	4.4

Illustration:
F242038-101



Illustration:
F242830-101 with
wheel curve

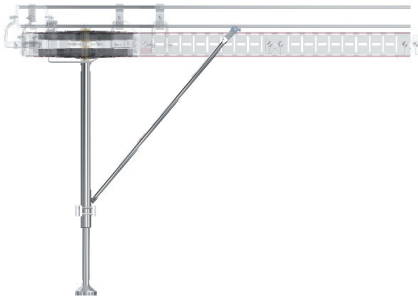
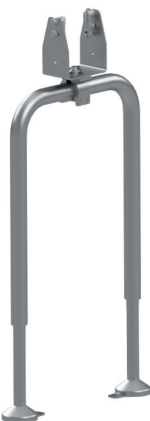

Illustration:
F241416-101



Illustration:
F242001-101



Legs (Conveyor)

We recommend using Fredrikson hygiene extendable leg system for the CS70 conveyors system. All legs are made of stainless steel material.

Guidelines for placement of legs:

- One standard leg in centre of each curve
- One leg for each package trap
- One leg for every 2-3 m
- One motorleg for each belt brake
- One motorleg for each motor

Part number	Variants	Belonging Part	Chain Height mm
F242038-101	Single	Conveyor	H=758-1008
F242038-102	Single	Conveyor	H=958-1208
F242038-103	Single	Conveyor	H=1158-1408
F241416-101	Double	Conveyor	H=295-365
F241416-102	Double	Conveyor	H=365-510
F241416-103	Double	Conveyor	H=500-770
F241416-104	Double	Conveyor	H=515-785
F242001-101	Double	Conveyor	H=774-1024
F242001-102	Double	Conveyor	H=974-1224
F242001-103	Double	Conveyor	H=1174-1424
F242001-104	Double	Conveyor	H=1524-1774
F242001-105	Double	Conveyor	H=1774-2024
F242001-106	Double	Conveyor	H=2474-2724
F242001-107	Double	Conveyor	H=1999-2249
F242830-101*	Single	Wheel Curve	H=758-1008
F242830-102*	Single	Wheel Curve	H=958-1208
F242830-103*	Single	Wheel Curve	H=1158-1408
F242830-104*	Single	Wheel Curve	H=1258-1508
F242830-201**	Single	Wheel Curve	H=758-1008
F242830-202**	Single	Wheel Curve	H=958-1208
F242830-203**	Single	Wheel Curve	H=1158-1408

* Strut length 820mm

** Strut length 500mm

Illustration:
F240998-111



Legs (Motor)

We recommend using Fredrikson hygiene extendable leg system for the CS70 conveyors system. All legs are made of stainless steel material.

Guidelines for placement of legs:

- One standard leg in centre of each curve
- One leg for each package trap
- One leg for every 2-3 m
- One motorleg for each belt brake
- One motorleg for each motor

Illustration:
F240998-121

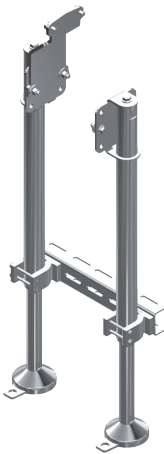
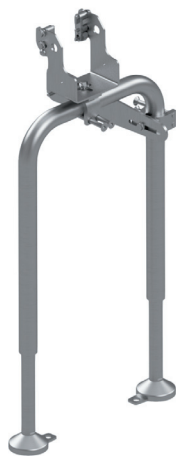

Illustration:
F241640-101



Part number	Variants	Belonging Part	Chain Height mm
F240998-108	Single	Drive Unit	H=539-789
F240998-109	Single	Drive Unit	H=344-594
F240998-110	Single	Drive Unit	H=539-789
F240998-111	Single	Drive Unit	H=828-1078
F240998-112	Single	Drive Unit	H=1028-1278
F240998-113	Single	Drive Unit	H=1228-1478
F240998-121	Double	Drive Unit	H=828-1078
F240998-122	Double	Drive Unit	H=1028-1278
F240998-123	Double	Drive Unit	H=1228-1278
F241640-101	Double	Drive & End Unit	H=763-1013
F241640-102	Double	Drive & End Unit	H=963-1213
F241640-103	Double	Drive & End Unit	H=1163-1413
F241640-104	Double	Drive & End Unit	H=1513-1763
F241640-105	Double	Drive & End Unit	H=1763-2013
F241640-106	Double	Drive & End Unit	H=2463-2713
F241640-107	Double	Drive & End Unit	H=1988-2238



Strut

Fredriksons struts is used to stabilize the conveyor in lengthwise direction.

Part number	Variant Length (mm)
F241370-101	820
F241370-102	1250



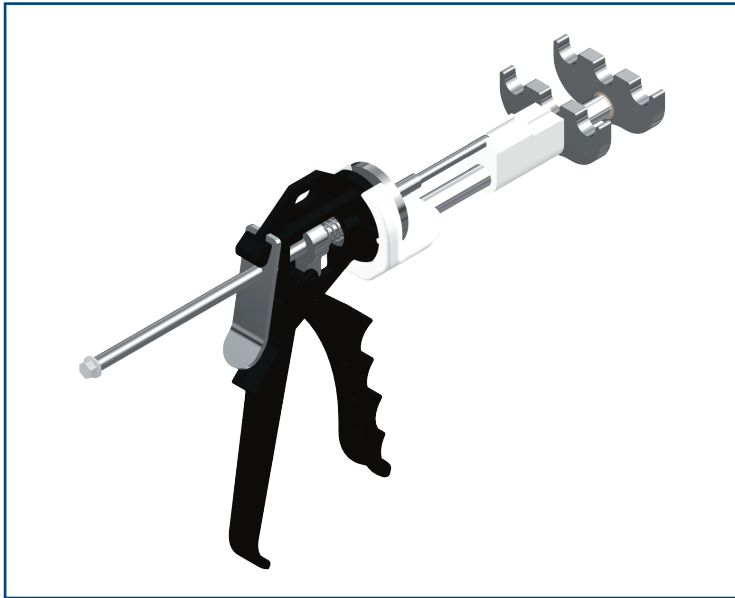

Chain Tool

Fredriksons Chain tool is used for splitting and joining chains.

Part number

F240245-202

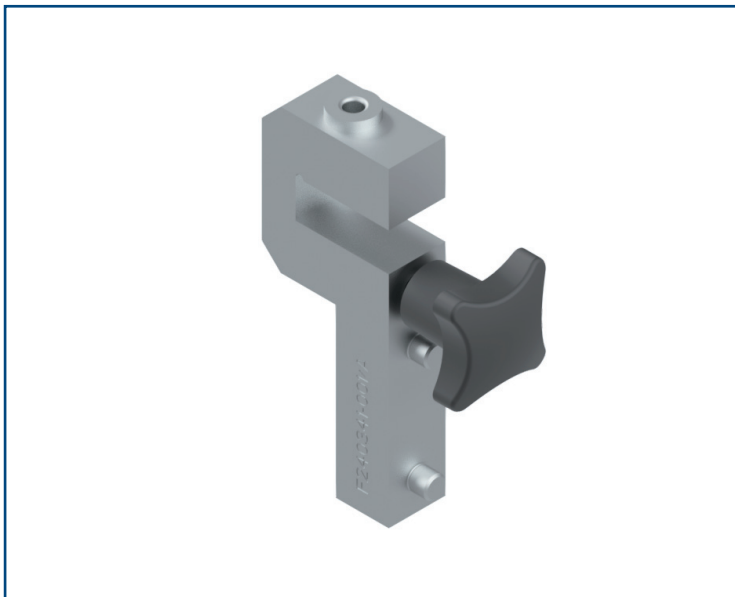

Drill Fixture

Fredriksons Drill fixture is used for drilling holes in side plates when assembling new sliding strips.

Part number

F240368-101

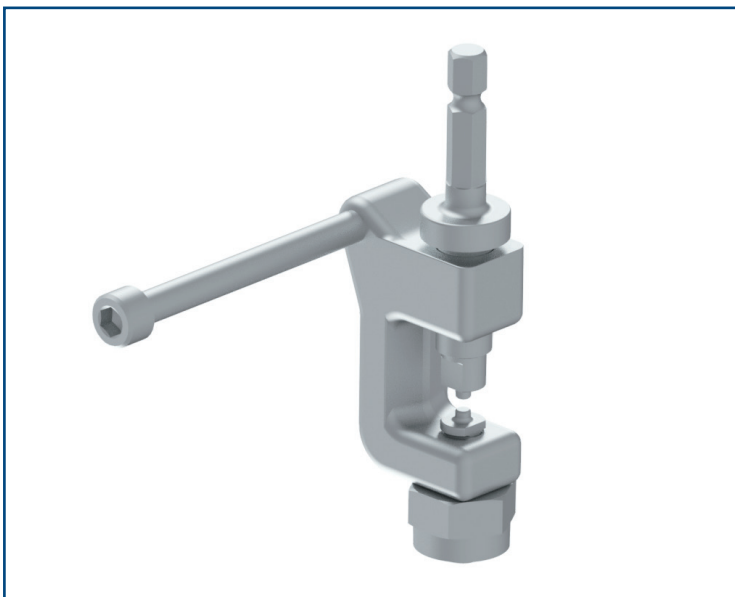

Rivet Tool

Fredriksons Rivet tool is used when mounting new sliding strip on the conveyor body.

Part number

F209371-101



Fredriksons is a part of the XANO Group

XANO consists of niche engineering companies in Sweden, Norway, Estonia, Finland, Poland and China. These companies provide manufacturing and development services for industrial products and automation equipment. They operate within well-defined niches and possess a high level of expertise within their respective technical fields. The Group's operation is divided into three business units: Industrial Solutions, Precision Technology and Rotational Moulding.

Industrial Solutions – contract assignments within sheet metal processing, in-house-developed conveyor systems and packaging machinery, hand wheels, handles and adjustable feet for furniture and shop fittings.

Precision Technology – component and system manufacture through advanced cutting machining of metal and plastic for the production of components with demanding requirements for quality and precision.

Rotational Moulding – manufacturing of plastic products in the form of components and systems through rotational moulding.



FREDRIKSONS

Fredriksons Verkstads AB • P.O Box 148 • SE-592 23 Vadstena
Phone: +46 143 296 00
info@fredriksons.se • www.fredriksons.se

Fredriksons Industry (Suzhou) Co. Ltd. • Suzhou Industrial Park
Phone: +86 512 6282 9600 • Fax: +86 512 6282 9609
www.fredriksons.cn