



Vertical Conveyor Unit

Elevate with Efficiency

Fredrikson's Vertical Conveyor

Transform your production line with the Fredrikson's Vertical Conveyor (VCU), specifically designed for the vertical transportation of single packages. Crafted from stainless steel, this system sets the standard for safety and hygiene in the industry, ensuring your operations meet the highest criteria.

The VCU not only offers a space saving solution but also promises fast installations and easy integration into your existing setup. It represents a leap forward in vertical conveying technology, providing a reliable, safe and hygienic way to elevate your production capabilities.

Flexible Installation

Choose between a separate electrical cabinet or one integrated directly into the conveyor system for streamlined efficiency

Unmatched Reliability & Safety

Engineered for dependable operation with an emphasis on safety and hygiene

Tailored to Your Needs

Customizable to fit your specific requirements, the VCU adapts to the capacity of your filling machine and package type

Compact & Efficient

Optimizes your workspace by using significantly less floor space compared to traditional spiral solutions

*Fredrikson's Vertical Conveyor
Where vertical transport meets
innovation and excellence*

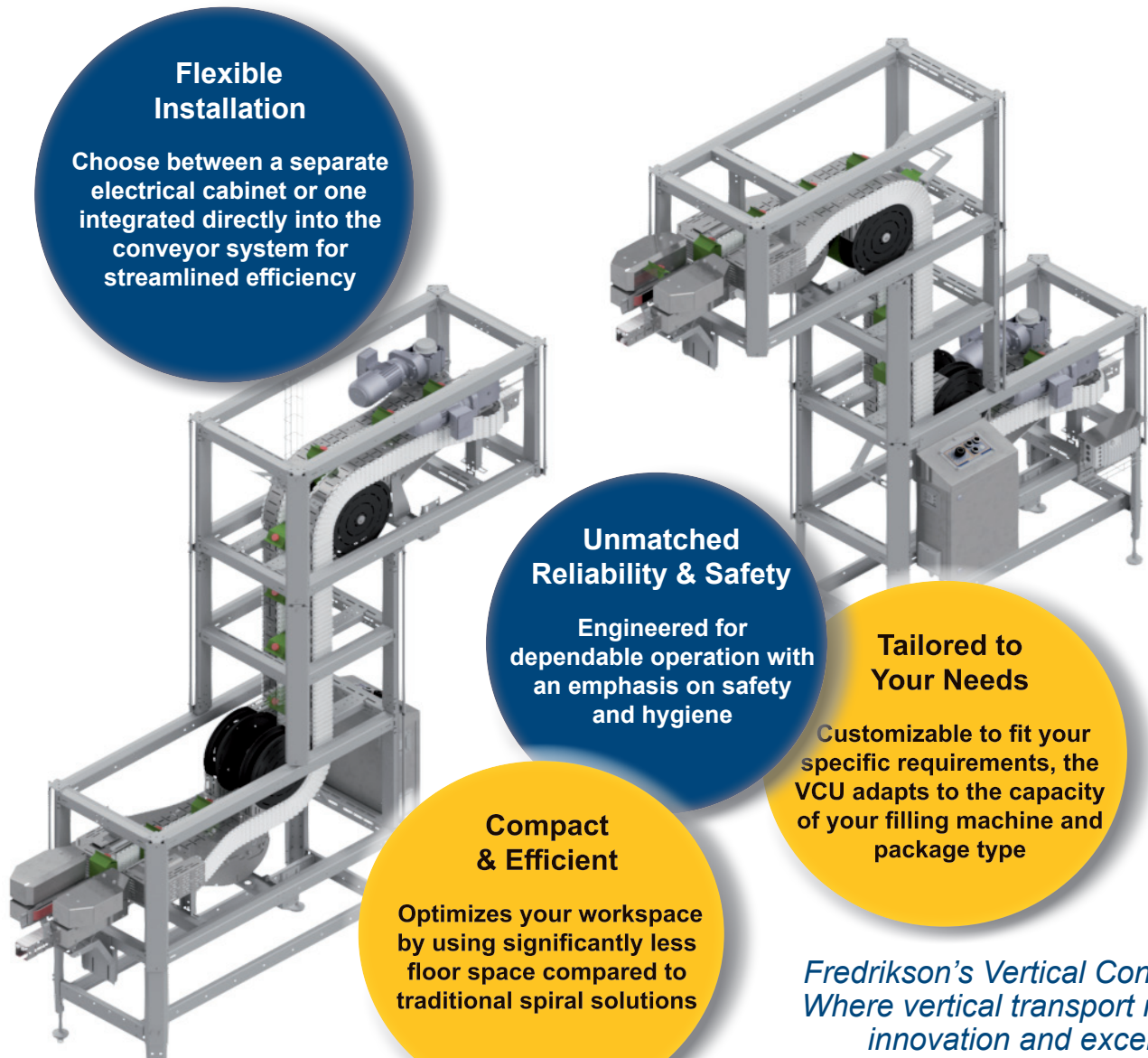



Technical data

Material.....Stainless steel EN1.4301
Package max. width..... 50 - 100 mm
Capacity max..... Varies with product specification
Noise emission..... ~70 dB
Infeed / Outfeed height..... Customized according to request

Electrical data

Material on Cabinet..... Stainless steel AISI 304L
Communication..... Profinet or relays
Phase..... 3N~
Frequency..... 50/60 Hz
Voltage 400 V
Power consumption..... Varies with product specification

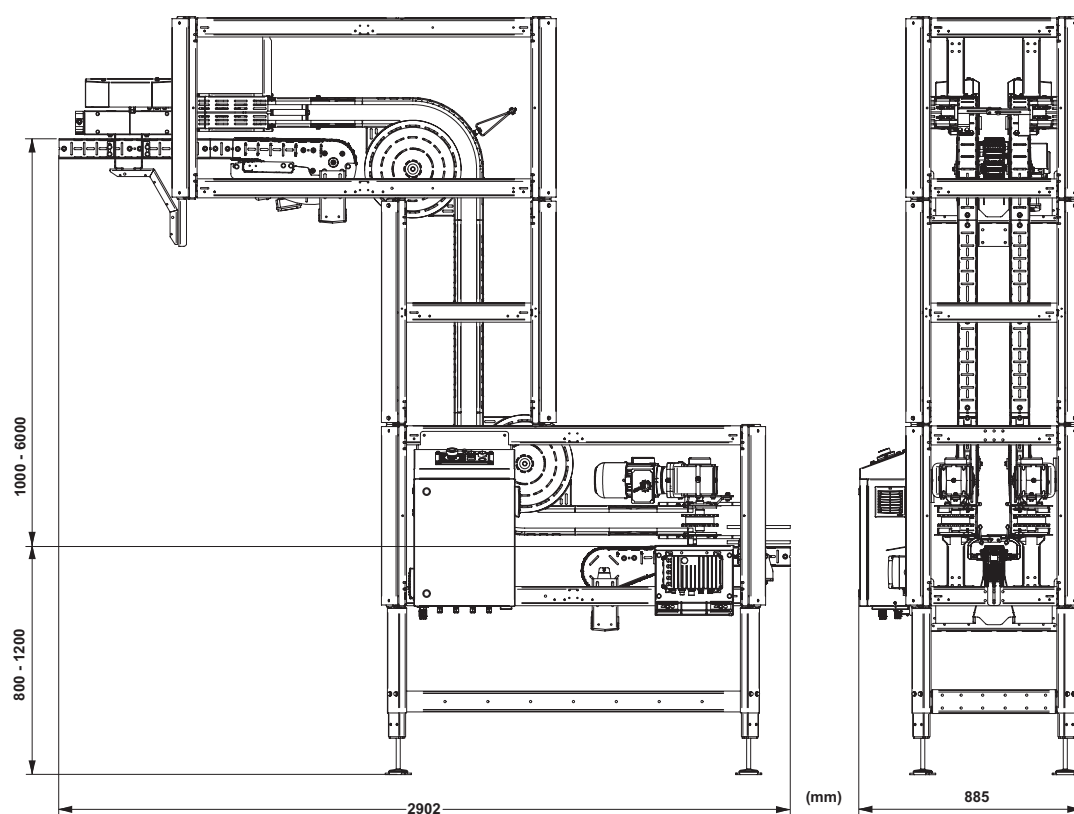

Fredriksons AB
P.O Box 148 • SE-592 23 Vadstena
Phone: +46 143 296 00
info@fredriksons.se • www.fredriksons.se

PART OF THE XANO GROUP