



Divider

Unlock the Potential of Fredrikson's Divider

Precision in Every Split

Increase your production capacity with Fredrikson's Divider, the innovative solution designed to distribute a single product flow into two or three separate streams with high accuracy. This state of the art unit dramatically improves traditional systems in terms of flexibility, speed and capacity, enabling a controlled and high production efficiency.

The compact design ensures that it integrates seamlessly with your existing setup, offering adjustable settings for percentage distribution and batch sizes without the need for emptying when changing lines.

Superior Capacity Performance

Surpass the limits of conventional dividers with our high capacity handling



Precision Splitting

Effortlessly divide one stream into two or three and easily adjust the percentage distributions for your different packaging lines

Versatile Flow Distribution

Customize the division to achieve varied percentage distributions effortlessly

*Fredrikson's Divider
Where cutting edge technology ensures every
division is a step towards greater productivity*



Technical data

Material	Stainless steel EN1.4301
Package width.....	40 – 120 mm
Chain width	70 mm
Min. Conveyor speed	0,33 m/s
Max. Conveyor speed	1 m/s
Min. Conveyor Length IN	1500mm
Max. Conveyor Length IN	2500mm
Min. Conveyor Length OUT.....	2500mm
Max. Conveyor Length OUT.....	5500mm
Entry/outfeed height	825-1100 ± 50mm
Capacity.....	≤30000p/hour*
Installation dimension.....	Width: 760 mm Length: 2410 mm
* Varies with product specification	

Electrical data

Material on Cabinet.....	Stainless steel AISI 304L
Communication.....	Profinet or relays
Voltage	3N/PE . 400 Vac
Current.....	16A
Frequency	50 Hz

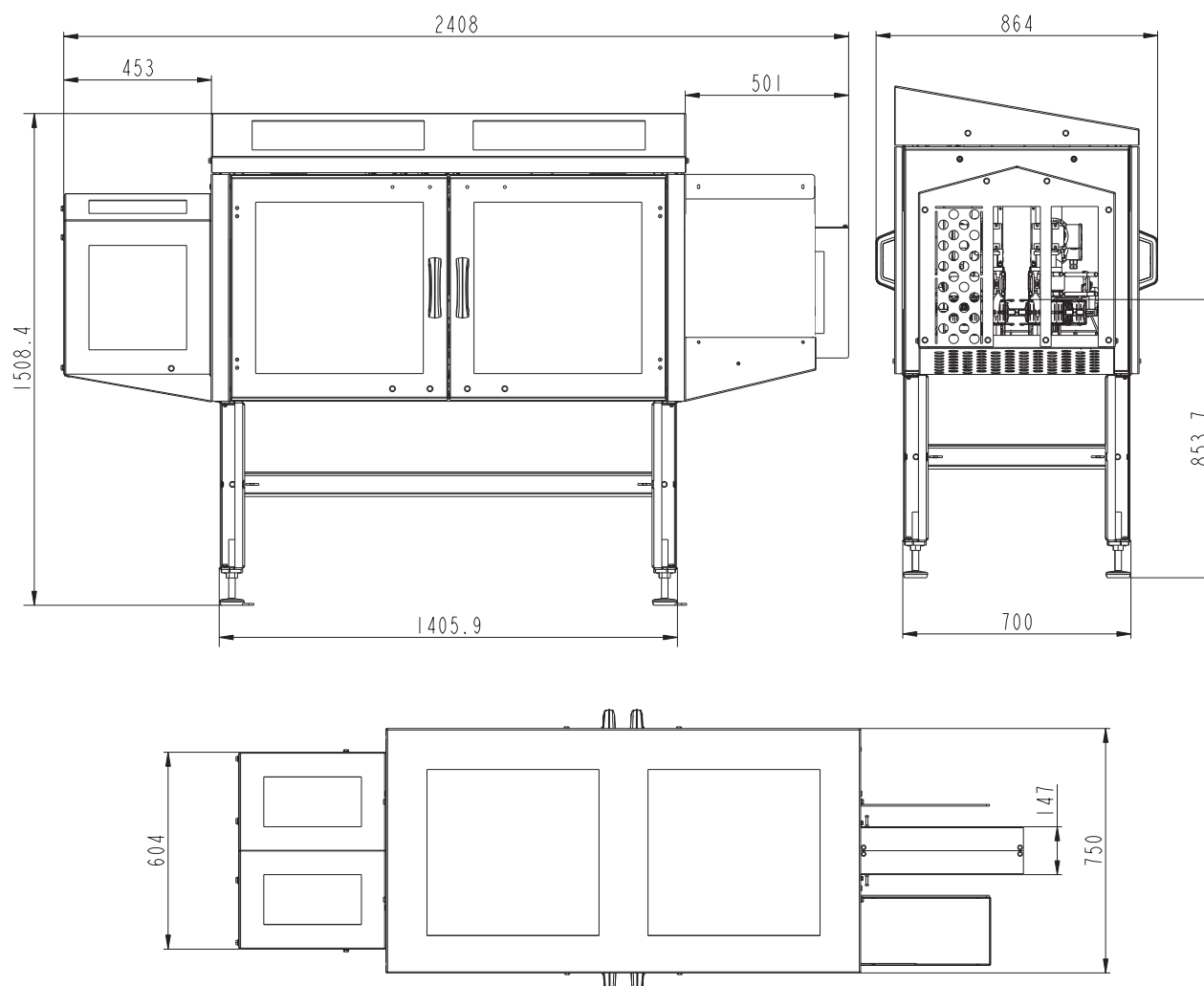

Fredriksons AB
P.O Box 148 • SE-592 23 Vadstena
Phone: +46 143 296 00
info@fredriksons.se • www.fredriksons.se

PART OF THE XANO GROUP