

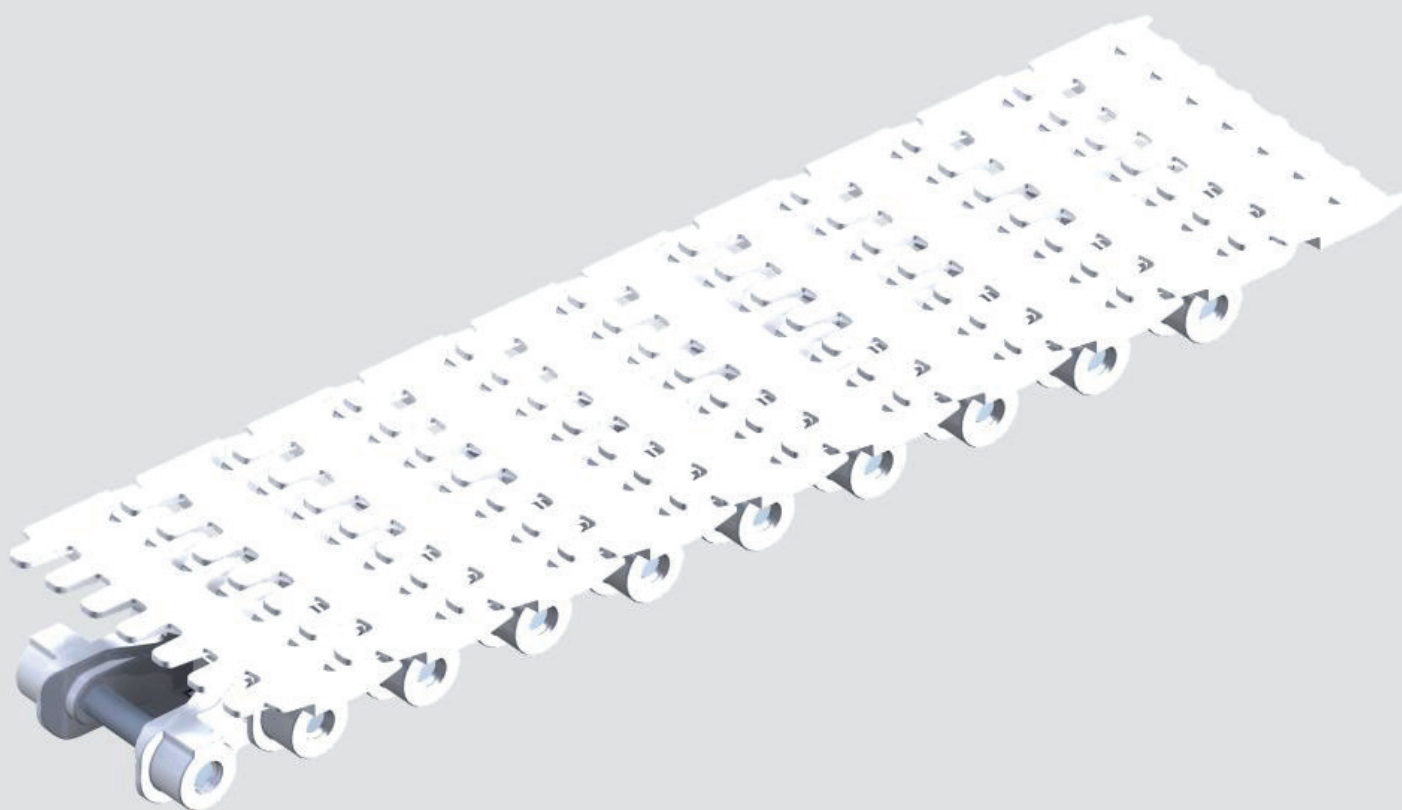

# Chain CS70

Fredriksons' plastic chain CS70 is developed for maximum hygiene, control & durability. The design protected plunge provides a longer life cycle and low noise level. The smooth contact surface is a major advantage in moving the goods. It is easy to clean thanks to its open design and still have a high safety level regarding trapping risks. It is developed according to safety regulations BS EN619 standard. Recommended surrounding temperature is -18 - +50 °C.





## Fredriksons

### An experienced partner

50 years of experience in developing and manufacturing conveyor system has provided us with the knowledge and experience required to create solutions – from details to complete systems.

We offer construction, assist in layout planning, manufacture the products and we can help you with installation, project management, and commissioning of the line.

We produce conveyors in our factories in Sweden and China. All our products fulfill legal demands and are produced in accordance with ISO 9001:2008, ISO 14001:2004, ISO 13485:2003 and ISO 3834-2.

### Market driven approach

We work in close cooperation with our customers to drive innovations and continuous improvements of our conveyor solutions.

The demand for Fredriksons' conveyor systems has been strong since the launch of our new range and the company has signed important orders for delivery.

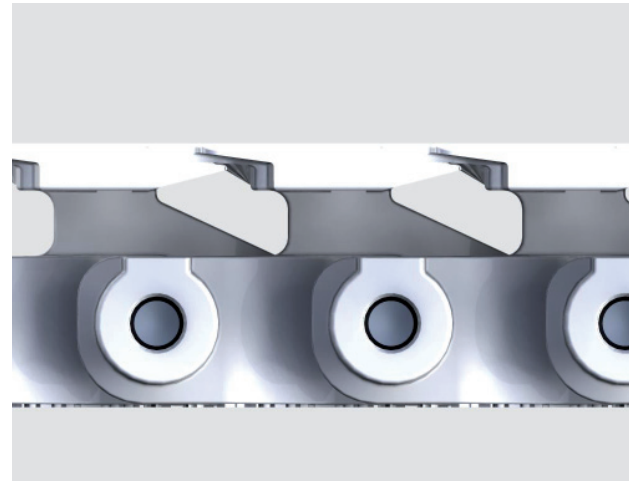

### Chain CS70 advantages:

- Hygiene
- High personal safety
- Modular
- Price
- Low noise level
- Energy efficient
- Low maintenance
- Durable
- Easy to clean

### Technical data

Material.....	Acetal (POM)
Goods width.....	20 – 120 mm
Chain width.....	70 mm
Capacity.....	100 m/min

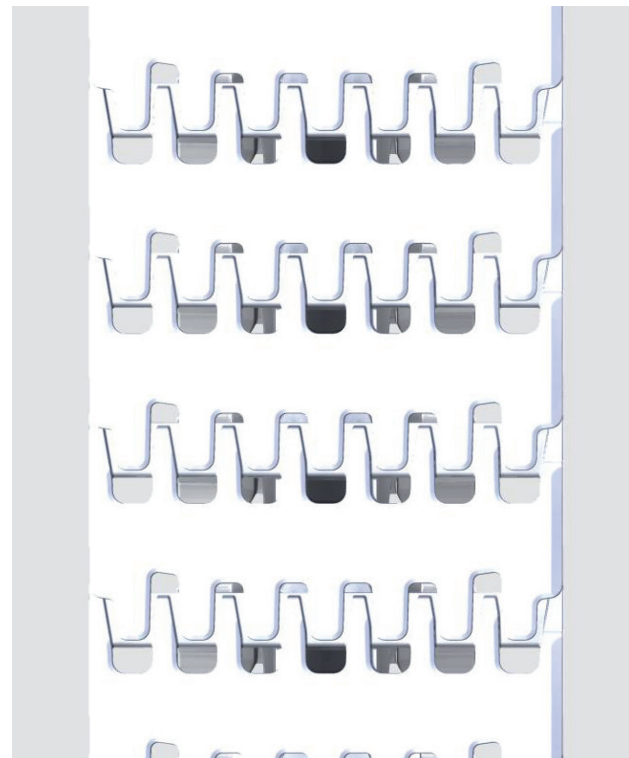

#### Fredriksons AB

P.O Box 148 • SE-592 23 Vadstena  
Phone: +46 143 296 00 • Fax: +46 143 296 09  
info@fredriksons.se • www.conveyorsolutions.se

PART OF THE XANO GROUP