



Converger

Discover the Power of Fredrikson's Converger

Efficiency Redefined

Elevate your production with Fredrikson's Converger, the smart solution for merging two product flows into one with unparalleled precision. Our innovative unit surpasses traditional systems in speed and capacity, ensuring a seamless bottleneck-free operation.

High Capacity Handling

Achieve more with less, outpacing conventional methods

Adjustable & Compact

Tailor the output to your needs in a design that fits your space

Effortless Merging

From two streams to one, without hassle

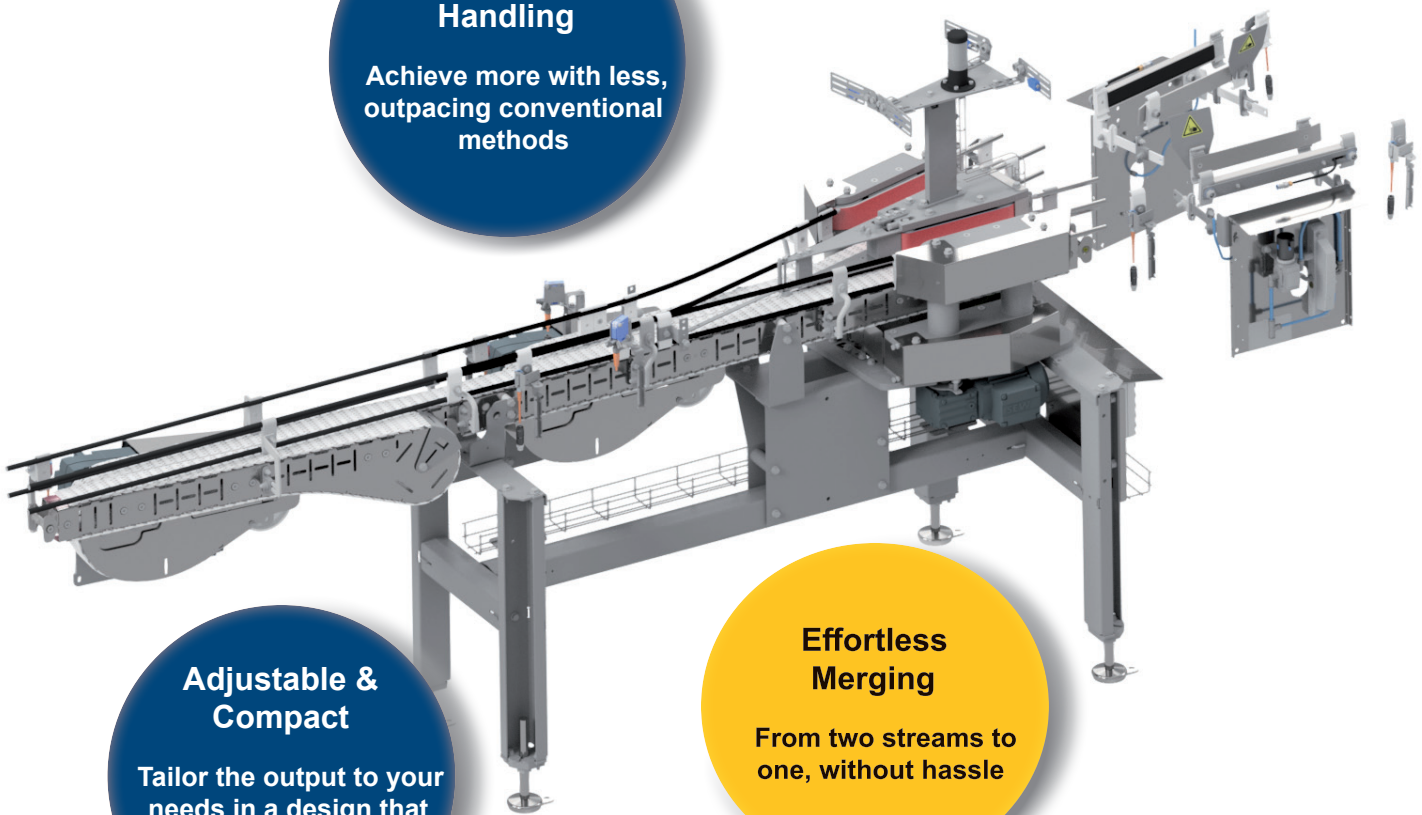

Optimize your production line with the Converger's advanced capabilities. Simple, efficient, it's the upgrade your conveyor system needs



Technical data

Material	Stainless steel EN1.4301
Package width.....	40 – 120 mm
Chain width	70 mm
Min. Conveyor speed	0,1 m/s
Max. Conveyor speed	1 m/s
Max. Conveyor Length IN (A).....	8000mm
Max. Conveyor Length IN (B).....	9000mm
Max. Conveyor Length OUT.....	4500mm
Entry/outfeed height	825-1100 ± 50mm
Capacity.....	Varies with product specification
Installation dimension.....	Width: 635 mm Length: 2050 mm

Electrical data

Communication	Profinet or relays
Voltage	3N/PE . 400 Vac
Current.....	16A
Frequency	50 Hz

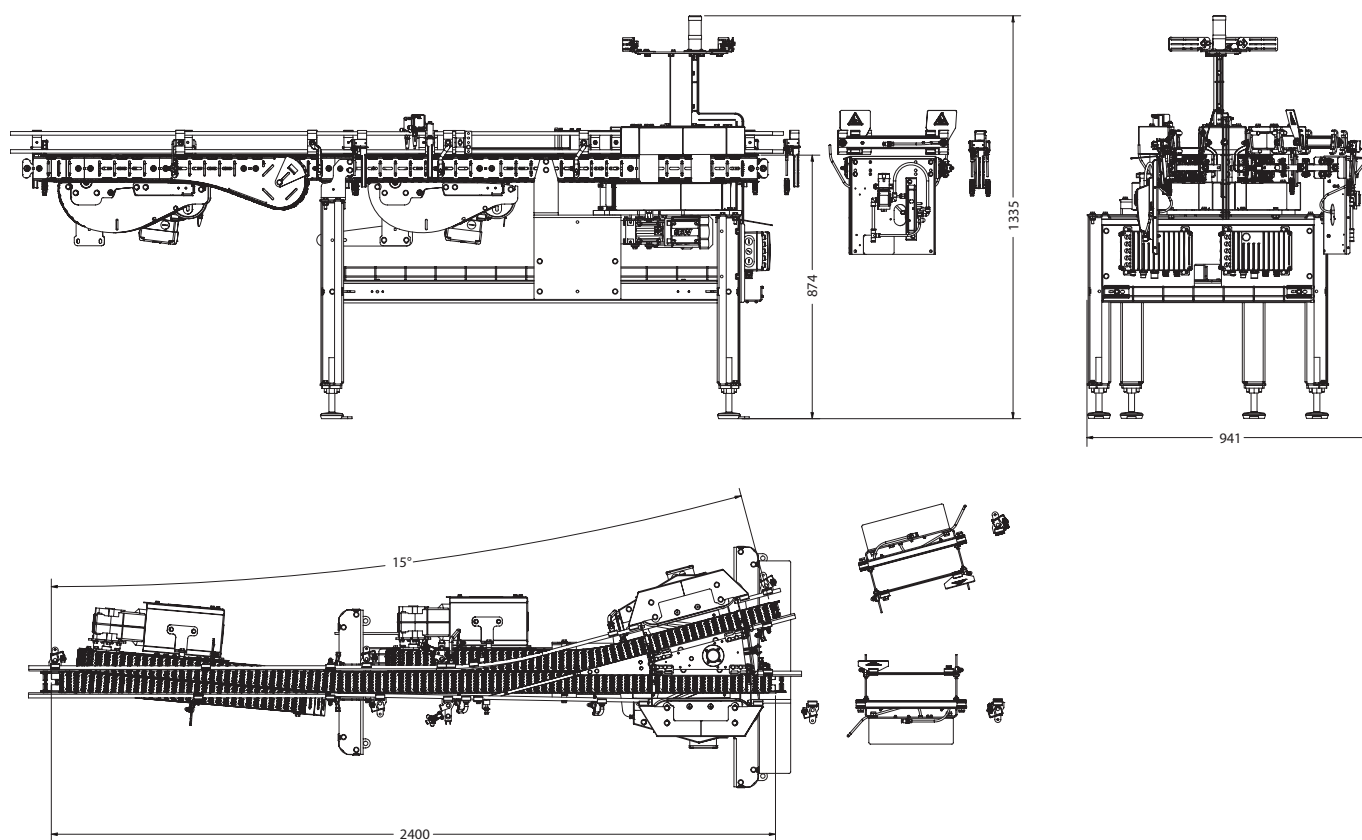

Fredriksons AB
P.O Box 148 • SE-592 23 Vadstena
Phone: +46 143 296 00
info@fredriksons.se • www.fredriksons.se

PART OF THE XANO GROUP